



**BradyJet™**

# **BradyJet™ J7300**

COLOR LABEL PRINTER

User Manual

---

## Copyright and Trademarks

### Disclaimer

This manual is proprietary to Brady Worldwide, Inc. (hereafter “Brady”), and may be revised from time to time without notice. Brady disclaims any understanding to provide you with such revisions, if any.

This manual is copyrighted with all rights reserved. No portion of this manual may be copied or reproduced by any means without the prior written consent of Brady.

While every precaution has been taken in the preparation of this document, Brady assumes no liability to any party for any loss or damage caused by errors or omissions or by statements resulting from negligence, accident, or any other cause. Brady further assumes no liability arising out of the application or use of any product or system described, herein; nor any liability for incidental or consequential damages arising from the use of this document. Brady disclaims all warranties of merchantability of fitness for a particular purpose.

Brady reserves the right to make changes without further notice to any product or system described herein to improve reliability, function, or design.

### Trademarks

BradyJet™ J7300 is a trademark of Brady Worldwide, Inc.

Microsoft, Windows, Excel, Access and SQL Server are registered trademarks of Microsoft Corporation.

All brand or product names referenced in this manual are trademarks (™) or registered trademarks (®) of their respective companies or organizations.

This system includes software known as Runtime Configuration, which is licensed from BlackBerry Limited. The following copyright notice applies exclusively to the Runtime Configuration software:  
© 1982-2023, BlackBerry Limited. All rights reserved.

© 2024 Brady Worldwide, Inc. All Rights Reserved.

Y5276524

Revision A

Brady Worldwide, Inc.  
6555 West Good Hope Road  
Milwaukee, WI 53223  
[bradyid.com](http://bradyid.com)

---

## Brady Warranty

Our products are sold with the understanding that the buyer will test them in actual use and determine for themselves the adaptability to their intended uses. Brady warrants to the buyer that its products are free from defects in material and workmanship, but limits its obligation under this warranty to replacement of the product shown to Brady's satisfaction to have been defective at the time Brady sold it. This warranty does not extend to any persons obtaining the product from the buyer.

THIS WARRANTY IS IN LIEU OF ANY OTHER WARRANTY, EXPRESS OR IMPLIED, INCLUDING, BUT NOT LIMITED TO, ANY IMPLIED WARRANTY OF MERCHANTABILITY OR FITNESS FOR A PARTICULAR PURPOSE, AND OF ANY OTHER OBLIGATIONS OR LIABILITY ON BRADY'S PART. UNDER NO CIRCUMSTANCES WILL BRADY BE LIABLE FOR ANY LOSS, DAMAGE, EXPENSE OR CONSEQUENTIAL DAMAGES OF ANY KIND ARISING IN CONNECTION WITH THE USE, OR INABILITY TO USE, BRADY'S PRODUCTS.

## Safety and Environment

Please read and understand this manual before using the BradyJet™ J7300 printer for the first time. This manual describes all of the main functions of the BradyJet™ J7300 printer.

### Precautions

Before using the BradyJet™ J7300 printer, please note the following precautions:

- Read all instructions carefully before operating the printer and prior to performing any procedure.
- Do not place the unit on an unstable surface or stand.
- Do not place anything on top of the unit.
- Keep the top clear of obstructions.
- Always use the printer in a well ventilated area. Do not block the slots and opening on the unit, which are provided for ventilation.
- Only use the power source indicated on the rating label.
- Use only the power cord that comes with the unit.
- Do not place anything on the power cord.
- This equipment is not intended for use by children.
- Avoid using the printer near water, in direct sunlight, under a spot light, or near a heating device.

---

## Technical Support and Registration

### Contact Information

Visit the Brady Knowledge Base at [supportbradyid.com/s/](https://supportbradyid.com/s/).

For repair or technical assistance, locate your regional Brady Technical Support office by going to:

- **United States:** [bradyid.com/techsupport](https://bradyid.com/techsupport)
- **Canada:** [bradycanada.ca/contact-us](https://bradycanada.ca/contact-us)
- **Mexico:** [bradyid.com.mx/es-mx/contacto](https://bradyid.com.mx/es-mx/contacto)
- **Latin America:** [bradylatinamerica.com/es-mx/soporte-técnico](https://bradylatinamerica.com/es-mx/soporte-técnico)
- **Europe:** [bradyeurope.com/services](https://bradyeurope.com/services)
- **Australia:** [bradyid.com.au/technical-support](https://bradyid.com.au/technical-support)
- **Asia Pacific:** [brady.co.uk/landing-pages/global-landing-page](https://brady.co.uk/landing-pages/global-landing-page)

### Registration Information

To register your printer go to:

- [bradycorp.com/register](https://bradycorp.com/register)

### Repair and Return

If for any reason you need to return the product for repair, please contact Brady Technical Support for repair and replacement information.

# Contents

## 1 • Introduction

<b>System Specifications</b> .....	<b>1</b>
Physical and Environmental Characteristics .....	2
<b>Ink Cartridge Specifications</b> .....	<b>2</b>

## 2 • Setup

<b>Unpacking and Setting up Printer</b> .....	<b>3</b>
What's in the Box .....	3
Registration .....	3
<b>Printer Components</b> .....	<b>4</b>
Exterior .....	4
Interior .....	5
Touchscreen .....	6
Navigation and Status Bar .....	7
Status Icons .....	7
Material Details .....	7
<b>Power</b> .....	<b>8</b>
Setup .....	8
Power Save Mode .....	8
Sleep Mode .....	8
<b>Software for Creating Labels</b> .....	<b>9</b>
<b>Connecting the Printer</b> .....	<b>10</b>
USB .....	10
Ethernet Network .....	10
Wi-Fi .....	11
<b>Installing the Printer Driver</b> .....	<b>13</b>
<b>Working with Labels and Ink Cartridges</b> .....	<b>14</b>
Installing Labels .....	14
Removing Label Supply .....	16
Installing or Replacing an Ink Cartridge .....	17
Aligning the Ink Cartridge .....	19
<b>Printer Settings</b> .....	<b>20</b>
System Configuration .....	20
About .....	22
Notifications .....	23
<b>Materials</b> .....	<b>23</b>

## 3 • Using System Tools

<b>Brady Print Utility</b> .....	<b>24</b>
<b>Printer Driver Settings</b> .....	<b>25</b>
Print Mode .....	26
Orientation .....	26
Printing from Other Programs .....	26

## 4 • General Operation

<b>Creating Labels</b> .....	<b>27</b>
Brady Workstation .....	27
<b>Files on the Printer</b> .....	<b>27</b>
Searching, Sorting, and Filtering .....	28
Saving Files to the Printer .....	29
<b>Printing</b> .....	<b>29</b>
Print Adjustments .....	30
Pausing a Print Job .....	31

## 5 • Maintenance

<b>Cleaning the Printer</b> .....	<b>32</b>
Ink Cartridge .....	32
Sensors .....	35
Touchscreen .....	35
<b>Clearing a Label Jam</b> .....	<b>35</b>
<b>Diagnostics</b> .....	<b>36</b>
System .....	36
Errors .....	36
Sensors .....	36
Test .....	36
<b>Recycling Material Plastics</b> .....	<b>37</b>
<b>Ink Cartridge Disposal</b> .....	<b>37</b>
<b>Installing Firmware Upgrades</b> .....	<b>38</b>
Upgrading via USB Drive .....	38
<b>Updating the Printer Label Library</b> .....	<b>38</b>

## 6 • Troubleshooting

<b>Help</b> .....	<b>39</b>
<b>Status Lights</b> .....	<b>39</b>
<b>Print Quality Issues</b> .....	<b>40</b>
<b>Warning and Error Messages</b> .....	<b>42</b>

## 7 • Label Specifications

<b>Continuous Labels</b> .....	<b>46</b>
<b>Pre-Sized Labels (Notched)</b> .....	<b>47</b>
<b>Pre-Sized Labels (Gap)</b> .....	<b>48</b>
<b>Linerless Labels (Notched)</b> .....	<b>49</b>

## 8 • Glossary

<b>Printer</b> .....	<b>50</b>
<b>Color</b> .....	<b>50</b>
<b>Ink Types</b> .....	<b>51</b>
<b>Common Ink Jet Terms</b> .....	<b>51</b>

## A • Regulatory Compliance

<b>Agency Compliance and Approvals .....</b>	<b>52</b>
United States .....	52
Estados Unidos .....	52
Canada .....	53
Europe .....	54
China .....	54
Taiwan .....	55
Turkey .....	55
<b>Wireless Regulatory Information .....</b>	<b>56</b>
United States .....	56
Mexico .....	57
Canada .....	57
European Union .....	57
Japan .....	59
Mexico .....	59
International .....	59
United Kingdom .....	60

# 1 Introduction

---

The BradyJet™ J7300 Color Label printer includes the following features:

- Auto sensing technology for quick and easy set up
- CMY and Black (K) ink cartridges deliver vibrant colors and readability
- Ideal solution for environments where durability is key
- Clear covers, LED status lights and a user interface provides immediate print job information
- High performance labels and tags with longer rolls and recyclable components
- NEW Brady Print Utility provides additional functionality
- Included Windows Driver has auto part sizing and can be used with 3rd party software packages
- Brady Workstation Labeling Software now with color tools such as ANSI and ISO color bars

## System Specifications

- Print length for continuous labels: 48" (1219 mm) maximum
- Minimum cut length 0.5 in. (1.27 cm)
- Maximum label width 4.25 in. (10.8 cm) without liner
- Maximum label width 4.13 in. (10.49 cm) with liner
- Minimum label length 0.25 in. (0.63 cm) with a liner width of at least 0.7 in. (1.8 cm)
- Print width: 4" (101.6 mm) maximum.
- Voltage: 100-240VAC, 50/60 Hz, 90 watts
- USB-C 2.0 for connecting to a computer
- USB-A host connector for USB drive
- Connect via Ethernet
- Wi-Fi option available on select models

## Physical and Environmental Characteristics

The BradyJet™ J7300 printer has the following physical and environmental characteristics:

Physical	U.S. Units	Metric Units
Dimensions	20" L x 14.5" W x 9.5" H	508 x 368.3 x 228.6 mm
Weight (printer only)	17.8 lbs	8.07 kg

**Note:** Consumable performance may vary.

Environmental	Operation	Storage
Temperature (Printer)	41° to 95° F (5° to 35° C) Recommended: 59° to 89° F (15° to 32° C)	-4° to 140° F (-20° to 60° C)
Relative Humidity (Printer)	10% to 60% (non-condensing)	10% to 80% (non-condensing)



**CAUTION!** Avoid using the printer near water, in direct sunlight, under a spot light, or near a heating device.

## Ink Cartridge Specifications

### *Shelf-Life*

- Unopened, sealed cartridges - 1 year
- Opened cartridges stored in printer - up to 3 months

### *Environmental Ranges*

Environmental	Operation	Storage
Temperature	41° to 95° F (5° to 35° C)	34° to 104°F (1° to 40° C)
Relative Humidity (Printer)	10% to 60% (non-condensing)	10% to 80% (non-condensing)

**IMPORTANT!** Unopened, sealed cartridges should be stored with the hang tag up.

## 2 Setup

---

### Unpacking and Setting up Printer

Carefully unpack and inspect the printer surfaces (interior and exterior) for possible damage during shipping.

**Note:** Be sure to remove any transportation protection from around or within the printer.

#### What's in the Box

- BradyJet™ J7300 Color Label Printer
- Power Adapter
- Power Cord (region specific)
- 6' USB Cable (If other USB cable is used, it must be 6' (2 M) or less.)
- Color Ink Cartridge (P-CMY-1) and Black Ink Cartridge (P-K-1)
- Alignment Roll (J-ALIGN) for ink cartridge alignment
- Printed Quick Start Guide
- Brady Workstation Insert
- USB Flash Drive containing the User Manual, Quick Start Guide, Printer Driver (which includes Brady Print Utility)



**Note:** Please keep the original packaging, including the box, in case the printer must be returned or repaired.

#### Registration

Register your printer on-line at [www.bradycorp.com/register](http://www.bradycorp.com/register) and receive free product support and updates!

## Printer Components

### Exterior



- |   |                        |    |                          |
|---|------------------------|----|--------------------------|
| 1 | Label Cover            | 6  | Power Button             |
| 2 | Touchscreen            | 7  | USB Port (for USB Drive) |
| 3 | Ink Access Cover       | 8  | USB C Port (to computer) |
| 4 | Exit Chute with Cutter | 9  | Ethernet Port            |
| 5 | Status Light           | 10 | Power Port               |

**Note:** The printer is equipped with a universal power supply and can be operated with a voltage of 100 to 240 V~, 50- to 60 Hz.

**Status Light Indicator** will illuminate blue when ready, orange when there is a warning or red when a problem prevents printing.

## Interior

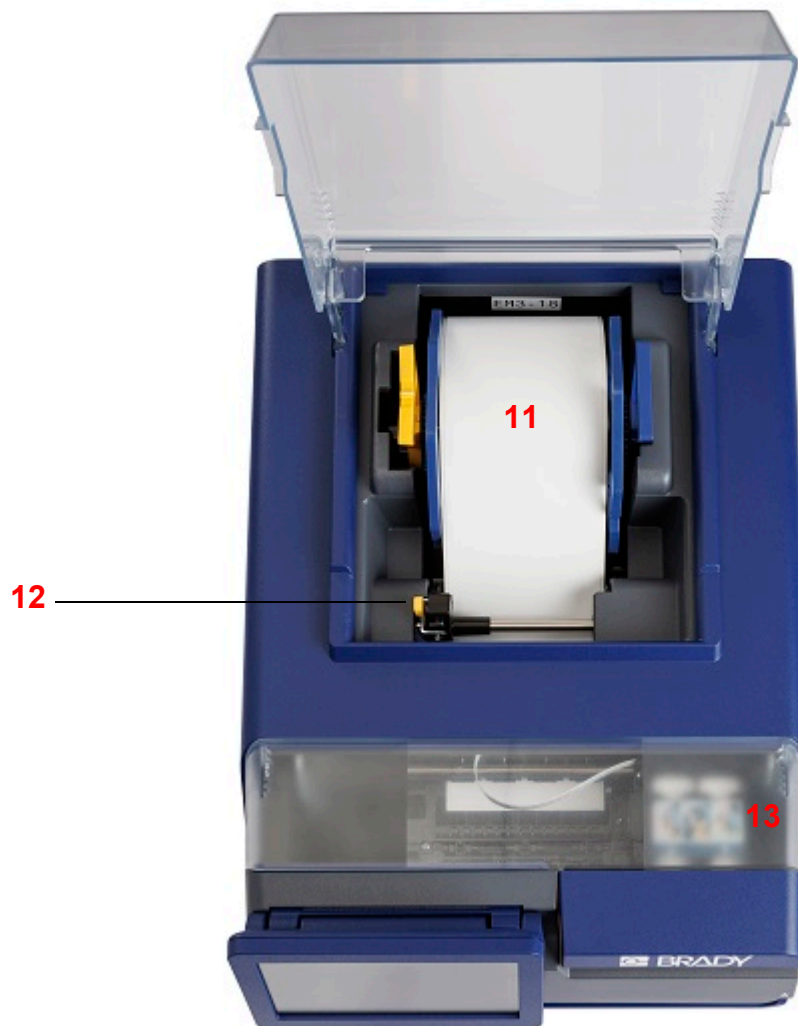

- 11 Label Roll
- 12 Media Guide
- 13 Ink cartridges under access cover

## Touchscreen

Use the printer's touchscreen to configure settings, check status, and print labels, among other functions. Touch the screen with your finger to make a selection.

**IMPORTANT!** Do not use a pen or other sharp object. Doing so may damage the touchscreen surface. If you choose to use a stylus (part number STYLUS-CAP), be sure to use only the soft rubber end.

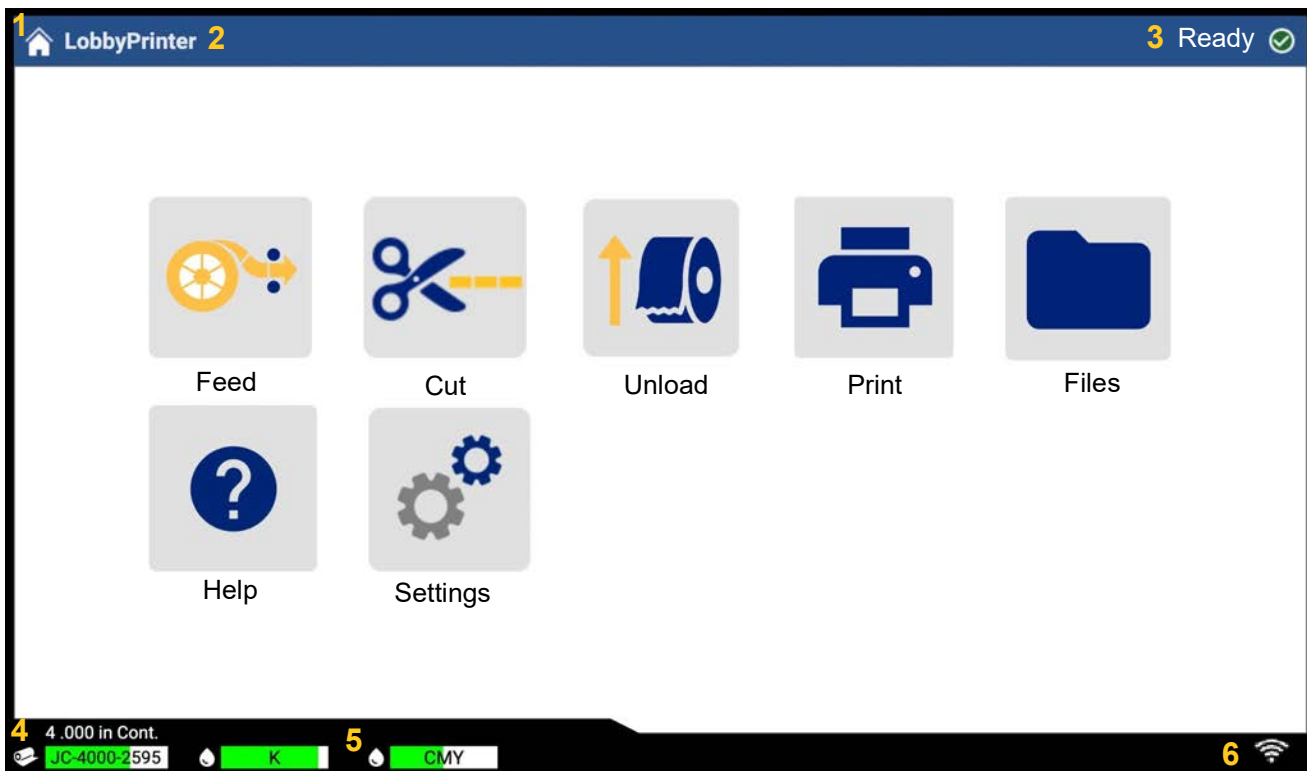

- |   |   |   |  |
|---|---|---|--|
| 1 | Home  | 4 | Label supply status, size and part number  |
| 2 | Printer name (default is the serial number) | 5 | Black (K) and Color (CMY) Cartridge level  |
| 3 | Print job status                            | 6 | Wi-Fi status, available on specific models |

## Navigation and Status Bar



Tap the home button at any time to return to the home screen.



While navigating the menus, tap the back button to return to the previous screen.

## Status Icons

The printer and material status icons in the status bar at the bottom of the home screen provide the following information.

Icon	Meaning
	The text beside this icon indicates the label material installed in the printer.
	The printer cannot read the smart-cell on the label supply. Label supply may not be installed, may be installed incorrectly, or the smart-cell may be corrupted.
	The printer is receiving data from a computer connected with a USB cable or from the network.
	Appears blue when connected to the Wi-Fi network or gray when not connected.

## Material Details

To see detailed information about the installed supplies, click the label or ink cartridge icon in the status bar to open the *Material Details* screen.



To close the *Material Details* screen, click the x in the upper right corner.

**Note:** Ink cartridge levels are estimates.

## Power

**IMPORTANT!** Unplugging the printer will disable essential printer self maintenance routines which keep the ink cartridges from drying out. Therefore, it is recommended to never unplug the printer.

### Setup

Plug the power cord into the power input port on the back of the printer and the other end of the power cord into an AC power outlet.

### Power Save Mode

When the printer is plugged in, you can leave it in a state of readiness all the time so that software can find the printer. Or you can choose to conserve power so that the printer automatically goes to sleep after a period of inactivity.

#### To set the inactive period:

1. Tap **Settings**.
2. Press **System Configuration > Power Save Mode**.
3. Choose **AC Power**.
4. Slide the time indicator dot left (decrease) or right (increase) for the amount of inactive time that can elapse before the printer automatically shuts down. Alternatively you can press the minus (-) button to decrease or the plus (+) button to increase the time.
5. Return to the home screen.

**Note:** When the printer is idle the screen and status light dim.

### Sleep Mode

When the printer is asleep the display and status light turn off and the system goes into a low power consumption state but does not require a cold start to turn back on. Automatic maintenance and cleaning routines will still run.

#### To put the printer to sleep:

With the printer on, press the power button.

#### To wake the printer up:

Touch the screen or press the power button.

## Software for Creating Labels

Install labeling software on your computer, set up the connection to the printer, then use the software to design labels and send them to the printer.

Brady Workstation software provides a variety of apps to simplify label creation for specific purposes. It also provides easy-to-use apps for custom label design and is optimized for full color applications. The printer comes with a license for the Brady Workstation Product.

### To install Brady Workstation:

1. Make sure your computer is connected to the Internet.
2. Go to [workstation.bradylid.com](http://workstation.bradylid.com).
3. Follow the instructions on the screen to download and install the software.

When you run the software and open an app that requires activation, follow the instructions on the screen to activate the software. Use the license ID and password on the printed insert that came with the printer.

Safety and Facility Identification and Product and Wire Identification suites within Brady Workstation allow you to import Excel data, do batch printing and, of course, give you the ability for full label creation as well as many other features.



Select the license type that best fits your needs.



#### Safety & Facility Identification Suite

Safety signs and labels



#### Product & Wire Identification Suite

Product, wire and component  
labels



#### Laboratory Identification Suite

Lab labeling

## Connecting the Printer

### USB

Connect to the labeling software using the supplied USB cable.

Plug the provided USB cable into the printer and the computer. Brady Workstation software automatically detects the printer when connected via USB cable.

**Note:** If you are not using Brady Workstation software, you need to install the printer driver. See [Installing the Printer Driver on page 13](#).

### Ethernet Network

This section describes how to configure the printer to communicate via an Ethernet (TCP/IP) connection. This method allows multiple computers to send label files to the printer.

If using a Windows driver it is best to configure the Ethernet connection before installing the driver. If the driver is already installed before configuring the Ethernet connection, you may need to edit the port settings for the printer in Windows to update the IP address.

#### To configure network settings on the printer:

1. Make sure the printer is turned on.
2. Connect an Ethernet cable (not provided) to the back of the printer and the other end to the Ethernet port on the computer or Local Area Network (LAN).
3. (optional) Create a name for the printer by going to Settings > Connection > Printer Name. The default name is J7300.
  - Printer installations using a host name perform best with a dynamically assigned IP address.
4. For IP Settings, select either the DHCP or Static check box.
  - DHCP addressing uses a DNS server to dynamically assign an IP address without user configuration.
  - For static addressing, you must supply the printer's IP address.
5. If Static was selected, connect the printer using the USB cable and fill in the following fields:
  - IP Address: Enter the printer's IP address.
  - Subnet Mask: Enter a subnet mask if you are using one.
  - Default Gateway: Enter the IP address of the default gateway.
  - DNS Server (Primary): Enter the IP address of the primary DNS server.
  - DNS Server (Secondary): Enter the IP address of the secondary DNS server.

Your changes will be automatically saved after the values are set. When finished, click the Home icon or navigate to another page.

## Wi-Fi

Connect to a Wi-Fi network either by searching for and selecting a network or by manually entering the network settings. Once connected, the printer can communicate with computers on that network.

**Note:** Wi-Fi capability is not available on all printers or in all countries.

**IMPORTANT!** Before configuring the Wi-Fi connection on an enterprise network, be sure the printer is set to the current date and time. The printer may not be able to establish the connection if the date and time is not current. See [Date and Time on page 21](#).

### Search to Connect

To connect to a Wi-Fi wireless network:

1. Tap **Settings**.
2. Tap **Connection**.
3. Tap **Wi-Fi Network** to turn on Wi-Fi.  
The printer searches for Wi-Fi networks and displays a list of networks found.
4. Touch and drag to scroll the list. (If you need to identify the network by static IP address or DHCP, see [Manually Enter Settings on page 12](#).)
5. Tap the network that you want to use.
  - If the network is not locked, simply tap it and the printer connects to it.
  - If the network is locked, as indicated by a lock symbol, tap the network and a key pad opens. Enter the password and tap .

**Note:** If your network uses WEP authentication, a menu displays instead so that you can enter both the password and the WEP index (key).

- If the network you need is not in the list, it may not be discoverable. Scroll to the bottom of the list and tap **Other**. Choose either **Personal Network** or **Enterprise Network**. The system displays settings appropriate to your selection. You may need information from your IT department to complete the settings.

## Manually Enter Settings

Use this method for networks that are hidden.

### To connect to a Wi-Fi wireless network:

1. Tap **Settings**.
2. On the *Settings* screen, select **Connection**.
3. Tap **Advanced Network Settings**.
4. Select **Wi-Fi** from the list.
5. Tap **IP Settings** and then tap one of the following.
  - **DHCP**: DHCP addressing is dynamic and the system uses a DNS server to obtain the printer IP address for you.
  - **Static**: Select static addressing to manually enter the printer's IP address.
6. Tap the back button to return to the *Wi-Fi* screen.
7. Fill in the remaining available settings with help from your network administrator.
8. Return to the home screen.

### To connect with Ethernet:

1. Tap **Settings**.
2. On the *Settings* screen, select **Connection**.
3. Tap **Advanced Network Settings**.
4. Select **Ethernet** from the list.
5. Choose **IP Settings** and then tap one of the following.
  - If your network uses DHCP to automatically assign IP addresses, tap DHCP.
  - If your network requires manually providing IP addresses, tap Static. Get assistance from your network administrator to fill in the IP address and other settings on the Network screen.
6. If Static was selected, fill in the following fields:
  - **IP Address**: Enter the printer's IP address.
  - **Subnet Mask**: Enter a subnet mask if you are using one.
  - **Default Gateway**: Enter the IP address of the default gateway.
  - **DNS Server (Primary)**: Enter the IP address of the primary DNS server.
  - **DNS Server (Secondary)**: Enter the IP address of the secondary DNS server.

**IMPORTANT!** If no DNS server is being used, enter 0.0.0.0

7. Tap on the back button to get to the Advanced Network Settings screen in order for the fields entered to take effect.
8. If DHCP was selected, no additional fields need to be entered.

## Installing the Printer Driver

If you are using Brady Workstation software, you generally do not need to install the printer driver. The exception being the Data Automation app within Brady Workstation does require the printer driver to be installed.

Additionally, if you would like to install the Brady Print Utility directly on your computer, rather than view it in Brady Workstation, the printer driver must be installed.

If you are using older Brady software or third-party software, you must install the printer driver. The printer driver can be found on the USB drive provided with the printer. It can also be downloaded from [BradyID.com](http://BradyID.com).

1. Turn on the printer, but do not physically connect it to the computer until prompted.
2. Insert the USB drive on your computer.
3. Navigate to the printer driver folder and double-click on it.
4. Double-click on the printer driver executable file and follow the on-screen instructions.

## Working with Labels and Ink Cartridges

Brady labels come equipped with smart-cell technology that enables the printer to recognize the type of label installed and automatically set many label formatting details. Only use labels that have the Brady Authentic logo.



The BradyJet™ J7300 utilizes pre-sized, circular, edge notch, continuous and gap label supplies. As long as the label supply is compatible with ink jet printing and is within the allotted width of no more than 4.25 in. (10.8 cm) without liner or 4.13 in. (10.49 cm) with liner, it will work in the printer.

### Installing Labels

If the tray accessory was purchased, tip the printer up and slip the tray under the printer between the four anchor posts. The tray catches the labels after they are cut.

1. Open the label cover.

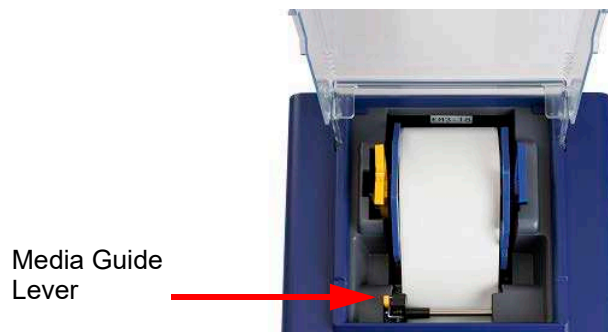

2. Press the yellow lever on the media guide and move the guide left far enough to fit the label roll.
3. Remove any shipping tape from the label supply roll to ensure that it can unroll freely, making certain that no adhesive portion is exposed.

**IMPORTANT!** Exposed adhesive surface can attach itself to the inner workings of the print mechanism and cause a jam.

4. Grasp the label roll with the labels coming off the top of the roll, the smart-cell on the right and the handles on the sides pointing up.
5. Hold the handles and place the label roll into the supply holder.

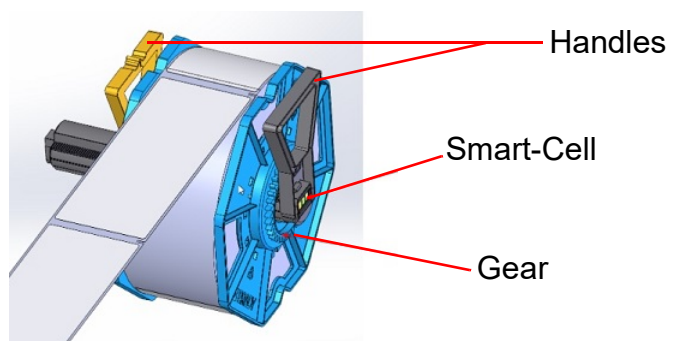

6. Place the leading edge of the label between the adjustable media guide (left side) and the stationary guide on the right side of the printer.



7. Move the media guide to where it barely touches the edge of the label supply.  
Guide labels forward until automatically fed through the printer. The printer will sense the label and automatically feed it through the printer. If the printer fails to feed the label supply, remove and reinsert the label roll then press the feed button on the screen to manually engage the feed roller.



**Note:** To ensure that the labels are fed straight be sure to push the label supply into the printer quickly until the entire front edge of the label is touching the feed roller. For wider labels use both hands to feed to maintain even forward pressure while you are pushing the labels into the printer.

## Removing Label Supply



**CAUTION!** Pulling the labels out of the printer without using the unload button can damage the printer.

**IMPORTANT!** Press the **Cut** icon on the home screen to remove any printed labels before pressing the unload button on the screen.

1. Press the **Unload** icon on the home screen.



2. Open the label cover.
3. Grasp the yellow and blue handles and lift straight up and out.

For information about recycling portions of the label roll, see [Recycling Material Plastics on page 37](#).

## Installing or Replacing an Ink Cartridge

The ink cartridges are labeled with a number ( **1** or **2** ) that corresponds to the numbers on the ink slots in the printer. It is important that each type of ink goes into the correct slot.

When the cartridge reaches 10% remaining you will be prompted, via the Brady Print Utility as well as a message on the printer screen and an orange status light, to replace the cartridge. If quality still looks acceptable you can choose to ignore this warning. However, you may waste labels if the cartridge runs out of ink before the next warning at 0%.

1. Open the ink access cover.
2. The cartridge carrier will align itself to the right of the print area, if not already in that position.
3. Press down on the yellow tabs on the ink cartridge cover to open.



4. Remove the new cartridge from its packaging and remove the protective tape covering the printhead.

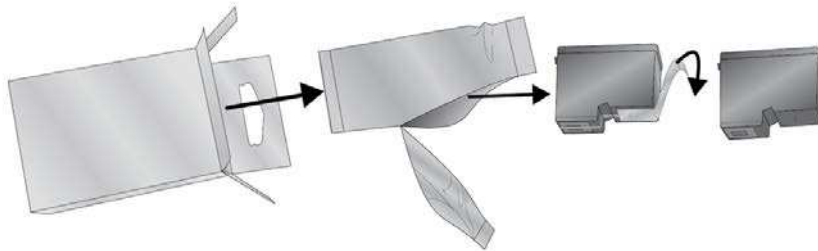

5. Remove an existing cartridge by pulling it out towards you.

6. Insert the new ink cartridge(s).

**IMPORTANT!** Put ink cartridge 1 in slot 1 and ink cartridge 2 into slot 2 as designated by the matching numbers on the ink cartridges and slots.



7. Push the ink cartridge cover downward until it snaps in place.
8. The printer will prompt you to align the cartridge; follow the on-screen instructions.  
A test label will print.
9. Verify the quality of the print on the test label.

**Note:** See [Aligning the Ink Cartridge on page 19](#) for more information.

## Aligning the Ink Cartridge

Ink cartridge alignment will adjust the cartridges for bidirectional printing and calibrate the printer to each individual cartridge. Alignment is prompted by the printer each time you install a new cartridge.

For alignment you will need to install continuous label supply that is equal to or wider than 2.95" (7.5 cm). The alignment roll (J-ALIGN) that was included with the printer should be used for ink cartridge alignment.

**Note:** If the wrong label supply is used, an Ink Cartridge Alignment Error message will display on the printer.

**Note:** If a print offset was used, this could impact alignment. See [Print Adjustments on page 30](#).

You may choose not to run alignment when prompted, but doing so can eventually affect print quality. If the labels contain streaks, banding, fuzzy text, or misalignment of colors, manually run [Aligning the Ink Cartridge on page 34](#).

A test label will be printed when running alignment.

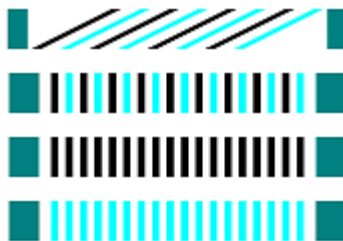

## Printer Settings

The first time you turn on the printer, instructions on the touchscreen walk you through the settings that must be configured. The following sections detail these settings should you need to change them in the future. There are also additional settings to consider when setting up the printer.

For an introduction to using the touchscreen, see [Touchscreen on page 6](#).

For information on power save mode, see [Power Save Mode on page 8](#).

### System Configuration

#### Language

**To set the language for text on the touchscreen:**

1. Tap **Settings**.
2. Tap **System Configuration**, then **Language**.
3. Tap the desired language.

You may need to scroll to see all available languages. Touch the screen and drag your finger up or down to scroll.

4. Tap the back button to go back to the previous screen or go to Home.

#### Virtual Keyboard

The printer displays a keyboard on the screen when you have to type data, such as when you name the printer. Because different languages use different sets of characters, you may need keyboards with different character sets. By default the printer uses the appropriate keyboard for the language setting. For example, if the printer language is set to Simplified Chinese, the printer will automatically display a keyboard with Simplified Chinese characters. If you only want to use the default keyboard, you do not need to change any keyboard settings.

**To select keyboards:**

1. Tap **Settings**.
2. Tap **System Configuration**, then **Virtual Keyboard**.  
A list of supported keyboards is displayed.
3. Tap the check box for each keyboard that you want to have available when using the printer. You can select multiple keyboards. The default keyboard (which is the same as the chosen language) is shown at the top of the list and cannot be deselected.

When you use the keyboard later, the default keyboard is shown. Tap the globe icon to switch to a different enabled keyboard. Each time you tap the globe icon, the display switches to another enabled keyboard.



### ***Measurement Units***

Set the unit of measurement to inches or millimeters.

#### **To set the unit of measure:**

1. From the home screen, tap **Settings**.
2. Tap **System Configuration**, then **Measurement Units**.
3. Tap the circle next to your selection.
4. Tap the back button to go back to the previous screen or go to Home.

### ***Date and Time***

Set the printer's clock to the current date and time.

#### **To set the date and time:**

1. From the home screen, tap **Settings**.
2. Tap **System Configuration**, then **Date and Time**.  
The left side of the screen displays the current settings.
3. To change the settings, tap the controls on the right.
  - **Use 24-hour format:** Tap the switch to change between 24-hour format and 12-hour format with AM and PM. When the switch is red, the printer uses 12-hour format. When the switch is green, the printer uses 24-hour format.
  - **Set date:** Tap to display date controls. To change the date, either tap on an element and select a new value, or tap the arrows above or below an element.
  - **Set time:** Tap to display time controls. To change the time, either tap on an element and select a new value, or tap the arrows above or below an element.
4. Tap the back button to go back to the previous screen or go to Home.

## Storage Location

Choose whether the printer accesses files from internal memory or external storage (USB drive).

### To set the storage Location:

1. From the home screen, tap **Settings**.
2. Tap **System Configuration**, then **Storage Location**.
3. Tap the desired value.
  - **Internal Memory:** Choose this option if the printer is directly connected to the computer with a USB cable or on a network. When you print a label from Brady Workstation software and choose the *Store* option, the print file is sent to the printer's internal memory. When you tap *Files* on the home screen, the printer accesses the list of files from internal memory.
  - **External Storage:** Choose this option when transferring files from one BradyJet™ J7300 printer to another. Insert a USB drive into the USB port on the printer. When you print a label from Brady Workstation software, the print file is sent to the USB drive. When you tap *Files* on the home screen, the printer accesses the list of files from the USB drive.
4. Tap the back button to go back to the previous screen or go to Home.

## LED Lights

Follow these steps to enable or disable the LED status light on the front of the printer.

- **Blue** - Ready/Idle
- **Orange** - Warning
- **Red** - Action Required

### To enable or disable LEDs:

1. From the home screen, tap **Settings**.
2. Tap **System Configuration**, then **LED Lights**.
3. Tap the switch to enable or disable.

## About

View system information:

- Firmware driver version
- Label library version
- Amount remaining of internal memory
- Amount remaining on external storage
- Serial number of the printer

### To view system information:

1. From the home screen, tap **Settings**.
2. Tap **About**.
3. Tap the back button to go back to the previous screen or go to Home.

## Notifications

Use this to suppress warnings on the printer about the wrong label type installed.

**To turn notifications off or on:**

1. From the home screen, tap **Settings**.
2. Tap **Notifications**.
3. Tap the switch to enable or disable.

## Materials

The following materials can be purchased for the BradyJet™ J7300.

- Color Ink Cartridge (P-CMY-1)
- Black Ink Cartridge (P-K-1)
- Alignment Roll (J-ALIGN), which is a 4" (101.6mm) wide x 50 ft (15.24m) length continuous, B-2569 Polyester, for ink cartridge alignment

There are over 100 label roll types available for use with the BradyJet™ J7300.







# 3 Using System Tools

## Brady Print Utility

The Brady Print Utility is used to interact with the printer for maintenance, gathering ink levels, print history, material calculations and other functions.

If you would like to install the Brady Print Utility directly on your computer, rather than view it in Brady Workstation, it automatically installs with your printer driver and can be accessed through the printer driver preferences or as a program on your Windows start menu.

1. Connect the printer to the computer via USB type C cord, Ethernet, or Wi-Fi (only if printer is Wi-Fi capable).  
The Brady Print Utility accesses most of the information it uses from the printer itself so the printer must be turned on and communicating for the program to open.
2. Go to **Start >Programs >Brady > Brady Print Utility**.  
The program consists of four sections that are arranged across the top of the window, as well as gauges along the right margin. The Brady Print Utility will only be displayed if the printer is idle (not printing).
3. Access the area relevant to what you want to achieve.

Sections	Features
 Queue	Display the jobs waiting to be printed. View, pause or delete jobs here.
 Print Calculator*	Estimate the approximate cost per label for large projects.
 Settings	Change language. Hide or clear the print calculator. Change units (inches or millimeters). View notifications.
 Maintenance	Clean or align the ink cartridges. Print a test label.
 About	Display driver, firmware version, serial number and software version.
 Gauges	View the amount remaining for ink and label supply.

\* Estimates in the print calculator are based on current labels being printed and are print job dependent. Pricing is input by the user. How many total and how many remaining labels can depend on several factors, such as:

- Humidity in the printer's environment.
- Length of time the ink cartridge is open which can lead to evaporation.
- Number of automated maintenance routines run between print jobs.
- Loss of accuracy if ink cartridges are switched between printers.

## Printer Driver Settings

Settings in the driver will NOT be applied to new or existing Brady Workstation labels (unless printing through Data Automation). Existing labels saved in Brady Workstation will not be affected since the preferences are saved with the label. Only labels printed through the driver will be affected by changing these settings.

### To find Printer Driver Settings:

1. Click the **Start** button on the computer.
2. Choose **Settings**.
3. Click on **Devices**, then **Printers & Scanners**.
4. Scroll through **Printers and Scanners** and click on **J7300**.
5. Click the **Manage** button.
6. Click **Printing Preferences**.



**Note:** Most applications allow you to change these same printer driver options from their “Print” screens. The settings you apply in printing preferences will remain until they are changed. If there are multiple J7300 printers, setting the preferences in one does not apply to all.

## Print Mode

The print mode can be changed when it suits different printing needs. It is accessed through the Windows Driver or in Brady Workstation.

**Draft** is the fastest, and can be used for test printing.

**Default** is used for general, all purpose labeling.

**Vibrant** can be used when stronger, brighter colors are needed.

**Precision** is best suited for small barcodes and labels.

**Note:** Exact color matching of the printed labels to the screen or changing RGB to CMY values may never be possible since there are factors that affect this that are out of the driver's control. The surface of the label reacts with the ink in the cartridge to produce the color. For this reason, when printing the same image to different types of labels with different surfaces the printed output can look entirely different.

## Orientation

There are two settings for orientation - portrait and landscape. If your text and graphics print left to right or as shown on the screen, select portrait. If you wish your printing to rotate 90 degrees from what you see on the screen, so it is printing horizontally, select landscape as your orientation. Remember, this does not change the width and height in the paper size setting. It is only a tool for viewing a label upright on screen that will be printed sideways on the printer.

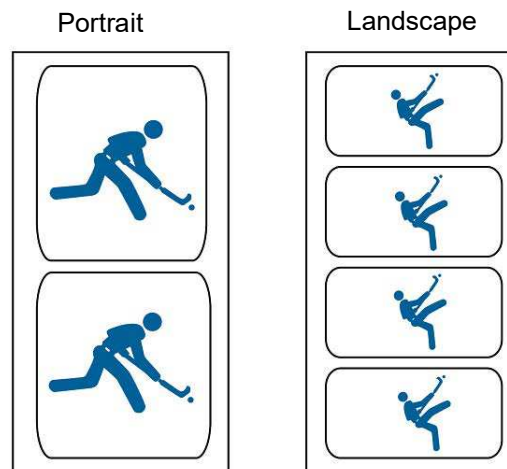

## Printing from Other Programs

Since this printer uses a standard Windows printer driver you can print from any application you would like. The driver communicates with the printer to know what label size is being used. Therefore, any file sent to the printer will automatically be re-sized to fit the installed labels.

# 4 General Operation





---

## Creating Labels

### Brady Workstation

The BradyJet™ J7300 is compatible with Brady Workstation desktop software. When you first create a label file, you specify the printer. This allows the software to provide features specific to your printer. Also, the software automatically recognizes all enabled and compatible materials. For operation of the printer with other software, refer to the documentation for your application.

## Files on the Printer

Button	Description
	<b>File Information</b> - Only visible when a single file is selected. Tap to display file information which consists of the following: <ul style="list-style-type: none"><li>• An image of the first label in the file.</li><li>• The label supply the file was created for.</li><li>• The size of the label.</li><li>• The number of labels in the file.</li><li>• The date the file was created.</li></ul> You can also delete or print the file from the information screen.
	<b>Print</b> - Tap to add all selected files to the print queue and begin printing.
	<b>More Menu</b> - Displays additional selections.
	<b>Enter</b> - Used after entering a file name in search.

Use the file list to select files to print and to see information about files.

#### To use the file list and add files to the print queue:

1. Tap **Files** on the home screen.  
The list is always available this way.
- or-

2. Tap **Print** on the home screen.  
The list is only available if printing is not in progress, otherwise the print screen displays.
3. Make sure the correct file location is selected. Tap the down arrow next to the file location and then tap the desired location.
  - Internal Memory shows files residing on the printer.
  - External Storage shows files residing on a USB drive that is plugged in to the printer.
4. Change the file view if desired. Tap the menu button and then tap one of the following:
  - Thumbnail View displays the files in a grid showing thumbnail images.
  - List View displays the a list of file names.
5. Find the files that you want to work with. Drag your finger up or down on the screen to scroll through the list of files. For help refining the list see [Searching, Sorting, and Filtering on page 28](#).
6. Tap one or more files to select them.  
Once selected you can view file information or print.

## Searching, Sorting, and Filtering

If the list of files is long, you can quickly find the desired file by searching, sorting, or filtering the list. To display the list of files see [Files on the Printer on page 27](#).

### To search for a label in the list:

1. With the list of files open, tap the **more menu** button.
2. Tap **Search**.
3. Use the keyboard displayed on the touchscreen to type all or part of a file name.  
The search is not case sensitive.
4. Tap the **enter** button.  
The list displays only files found in the search.
5. To clear the search and display all files again, tap the X next to the search term above the list.

### To sort the list:

1. With the list of files open, tap the **more menu** button.
2. Tap **Sort**.
3. Tap one of the following options.
  - Name sorts alphabetically by file name. Tap Name again to switch the sort direction between a-z or z-a.
  - Last modified sorts by date. Tap last modified again to switch the sort direction from newest to oldest or vice versa.
  - Number of labels sorts by the number of labels in the file. Tap number of labels again to switch the sort direction from most to least or vice versa.
4. Tap the blue checkmark when done.

**To filter the list by file type:**







1. Tap **Files** on the home screen.  
Filtering is not available from Print because only documents (label files) are printed.
2. Tap the **more menu** button.
3. Tap Filter and then tap Documents, Images, or Fonts.  
Documents are label files. Graphics and fonts are used in scripts.



**Saving Files to the Printer**

Only .prn files can be saved to the printer. Files can be added to the printer using a USB drive, an Ethernet cable or over Wi-Fi.

**Printing**

The following table describes the controls and information on the touch screen when a print job is running or paused.

Button	Description
	Goes to the next label. (Not available if the print file contains only one label.)
	Goes to the previous label. (Not available if the print file contains only one label.)
	Goes to the last label in the file. (Not available if the print file contains only one label.)
	Goes to the first label in the file. (Not available if the print file contains only one label.)
	Start or resume printing.
	Pause printing.
label number	Displays the current position in the label file as well as the total number of labels. Tap the current label number (within the rectangle) to jump to a particular label. A keypad opens. Tap the label number on the keypad and then tap the enter button.

Button	Description
	Cancel. Only available when printing is paused.
	More Menu. Provides a control to turn on the print on demand feature for the current print job only. For a description of the feature see <a href="#">Print on Demand on page 18</a> .

In most cases you will print directly from your label creation software on your computer or laptop. It is also possible to print from the printer's internal memory or external storage (a USB drive).

**To print directly from the printer:**

**Note:** If printing from external storage, plug the USB drive into the front of the printer.

1. Tap **Print** on the home screen.
2. Tap the **down arrow** on the left.
3. Select Internal Memory or External Storage.
4. Select the file to print and press **OK**.
5. If the label is not set to automatically cut, use the Cut icon on the home screen.

## Print Adjustments

These settings will be used on all print jobs. If you want to change them in a single job, be sure to either change them back or reset to the factory default settings when you are done. For an introduction to using the touchscreen, see [Touchscreen on page 6](#).

### *Print Position*

Adjusts the vertical and horizontal position of the contents on the label.

The printer will detect where to start the printing based on the pre-sized label or through-hole that corresponds to the start of the label. However, due to variations in the left margins and other variables it may be necessary to fine tune these settings at the beginning of each roll.

**To set the print position:**

1. Tap **Settings**.
2. Tap **Print Adjustments**, then **Print Position**.
3. Adjust the horizontal (x-axis) or vertical (y-axis) using the arrows.  
The on-screen example will move with each arrow click.
4. To reset the position, click the reset defaults button .
5. Print a label to test the setting and adjust as needed.
6. Tap the back button to go back to the previous screen or go to Home.

### *Cut Automatically*

Set whether the labels are cut as determined by the software, between labels, at the end of the job or never.

**To set the cut:**

1. Tap **Settings**.
2. Tap **Print Adjustments**, then **Cut Automatically**.
3. Make your selection.
4. Tap the back button to go back to the previous screen or go to Home.

***Print on Demand***

Print on demand causes the printer to wait for input on the touchscreen before printing the next label in the file. When Print on Demand is off, all labels in a file are printed without waiting in between.

1. Tap **Settings**.
2. Tap **Print Adjustments**.
3. Tap the **On/Off switch** on the right side of the screen.  
The icon will be blue when on and gray when off.

**To override print on demand:**

1. Tap the yellow circle to pause printing.
2. Tap the three dots in the upper right.
3. Turn off **Print on Demand** for this print job.

**Pausing a Print Job**

If the yellow pause icon on the printer's touchscreen is pressed, and print on demand is enabled, the current label will complete and the printer will pause at the current position. Additional print jobs sent to the printer will be held in the queue until printing is resumed. While paused, print jobs waiting in the queue can be rearranged with the exception of the job currently being printed.

When the printer is paused, the current label will finish printing, get cut and the job will be paused and printing can be resumed. Additionally, a dialog box will appear on the printer's screen with a Pause Now button. Clicking on Pause Now will immediately stop printing, including the current label, and the current print job will be canceled.

When pausing in the Brady Print Utility Status the print job can be restarted or canceled.

# 5 Maintenance

---

## Cleaning the Printer

**IMPORTANT!** Always keep the printer plugged in and turned on. The printer will do periodic maintenance to help avoid the printheads from getting clogged.

The outer case of the printer can be cleaned with an isopropyl alcohol or soapy water and a lint-free cloth.

### Ink Cartridge

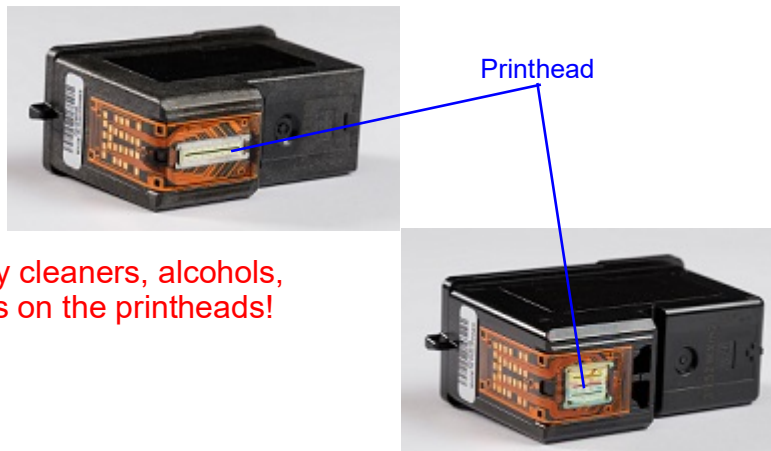

**Do NOT use any cleaners, alcohols, or other solvents on the printheads!**

It may be necessary to clean the ink cartridge printheads if you notice reduced print quality.

#### To clean the ink cartridge:

1. Open **Brady Print Utility**.
2. Select the **Maintenance tab**.
3. Click **Clean Ink Cartridges**.
4. Under the Maintenance tab, click **Print Test Label**.

If print quality is still an issue, a cartridge printhead may have become slightly dried out or clogged.

#### To clean the ink cartridge printhead:

1. Gather two paper towels and one glass of water.
2. Fold the paper towels four times each.
3. Soak both paper towels for five seconds in the glass of water.
4. Remove paper towels but do not squeeze out the excess water.

5. Remove the ink cartridge from the printer.
6. Place one of the paper towels on the printhead, press down, then leave for 30 seconds.  
This will “wick” away some additional ink.

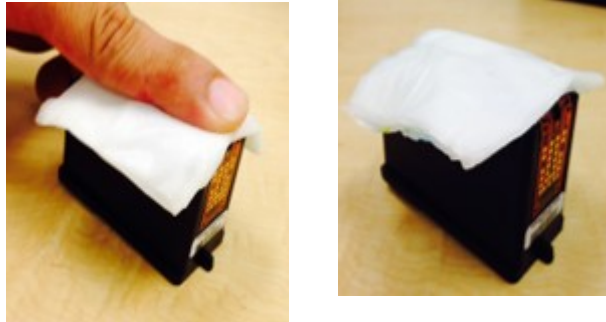

7. Remove paper towel from printhead and discard.
8. Lay the second paper towel on a flat, hard surface.
9. Firmly press printhead onto the paper towel and drag cartridge down.  
If you do not see all three colors on the paper towel (CMY cartridge only), repeat steps until all three colors are present.



10. Dry excess water from the printhead making sure the entire area is completely dry.

**IMPORTANT!** Printer damage may result if printhead contacts are not completely dry!

11. Repeat the process with the other ink cartridge.
12. Install both ink cartridges into the printer.
13. Open Brady Print Utility.
14. Select the **Maintenance tab** and click **Clean Ink Cartridge**.
15. Print a test label from the **Maintenance tab** in Brady Print Utility.

### *Aligning the Ink Cartridge*

**Note:** If a print offset was used, this could impact alignment. See [Print Adjustments on page 30](#).

#### **To align the ink cartridge from the Print Utility:**

1. Open **Brady Print Utility**.
2. Select the **Maintenance** tab.
3. Click **Align Ink Cartridges**.
4. Follow the on-screen instructions.

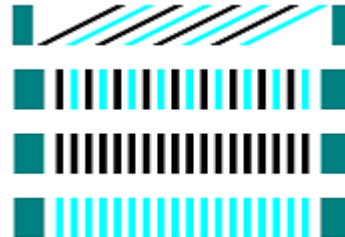

#### **To align the ink cartridge on the printer:**

1. Tap **Settings**.
2. Tap **Maintenance**.
3. Tap **Align Ink Cartridges**.
4. Follow the on-screen instructions.

### *Storing the Ink Cartridge*

Keep new ink cartridges in their original packaging, standing upright, until ready for use in the printer. Do not remove ink cartridges from the printer unless replacing or cleaning. If a used ink cartridge must be stored outside the printer, stand it upright in an air tight container.

## Sensors

Sensors can build up dust over time resulting in errors because the printer cannot detect the labels or the position of the labels. To help avoid this, keep the label cover closed at all times.

### To clean the label tension sensor:

1. Open the label cover and remove the label roll.
2. Use a can of compressed air to blow dust away from the sensor.
3. Replace the label roll and close the cover.

## Touchscreen

**Note:** Use only a lint-free cloth dampened with isopropyl alcohol. Other cleaners may contain ammonia, soap, or acids which can damage the screen.

### To clean the touch screen:

1. Lightly moisten a soft (non-scratching) cloth with isopropyl alcohol or use a pre-moistened swab from the Brady Cleaning Kit PCK-6.
2. Gently wipe the display screen until clean.
3. Remove excess isopropyl alcohol with a dry, soft (non-scratching) cloth.



## Clearing a Label Jam

If there is a label jam, press the Unload icon on the home screen of the printer. Remove the label roll, cut off bent or damaged labels, reload labels. If the Unload icon is grayed out, the jam is impeding movement of the carriage. Open the label cover, move the media guide to the left, grasp both sides of the labels close to the leading edge and gently pull out from the printer. Cut off any damaged portion of the label roll and re-install the labels.

## Diagnostics

If the need should arise to call Technical Support, information regarding the printer and printer usage can be found under Diagnostics. This is split into four categories, which can be accessed by going to Settings > Diagnostics.

### System

This provides information about:

- Printer serial number
- Firmware version
- Warranty start date
- Usage in terms of number of labels printed and cut
- Connectivity: USB, Ethernet, and Wi-Fi

### Errors

When the status light is orange, indicating a warning, the corresponding message can be found here. To export the entire log, tap the message followed by the export icon at the bottom of the screen. The log will be saved to the external storage as long as there is a USB drive in the port on the printer.

### Sensors

Internal sensors that are not user accessible, but can provide information to Technical Support.

### Test

Allows you to print a test label.

## Recycling Material Plastics

Label rolls need to be recycled in accordance with local regulations. Before recycling, the used roll must be pulled apart to release the individual components which then must be recycled in the correct recycling bins.

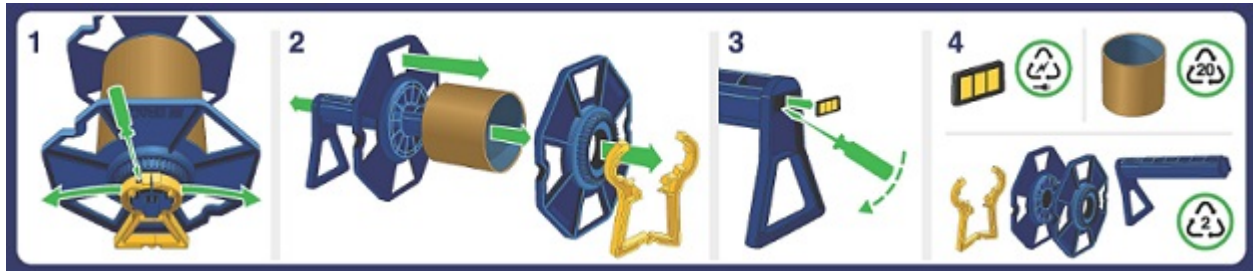

## Ink Cartridge Disposal

**BLACK** - This product is not a listed hazardous waste in accordance with Federal Regulation 40 CFR Part 261. If discarded in its purchased form, this product would not be a hazardous waste either by listing or by characteristic. However, under RCRA, it is the responsibility of the product user to determine at the time of disposal whether a material has been contaminated and should be classified as a hazardous waste. Disposal is subject to local, state and federal regulations.

**CMY** - Disposal of this product, solutions and any by-products should at all times comply with the requirements of environmental protection and waste disposal legislation and any regional local authority requirements. Dispose of surplus and non-recyclable products via a licensed waste disposal contractor. Waste should not be disposed of untreated to the sewer unless fully compliant with the requirements of all authorities with jurisdiction. Waste packaging should be recycled. Incineration or landfill should only be considered when recycling is not feasible. This material and its container must be disposed of in a safe way. Empty containers or liners may retain some product residues. Avoid dispersal of spilled material and runoff and contact with soil, waterways, drains and sewers.

## Installing Firmware Upgrades

Upgrades to firmware (printer system software) are available online. For information on how to locate the current firmware version on your printer, see [About on page 22](#).



**CAUTION!** Do not interrupt printer power during an upgrade.

### Upgrading via USB Drive

To upgrade firmware using a USB drive:

1. On a computer, go to the technical support website for your region. See [Technical Support and Registration on page iv](#).
2. Find firmware updates.
3. Find the most recent BradyJet™ J7300 firmware upgrade.
4. Download the firmware.
5. Save the downloaded file to a USB drive.
6. Connect the USB drive to the USB port on the printer. The printer recognizes the upgrade file and displays a message on the touchscreen.
7. Follow the instructions on the touchscreen. When the upgrade is complete, the printer restarts.



## Updating the Printer Label Library

Printer Label Library files are included in a database of label and ink part information that enables the printer to work optimally with various supplies.

Update Label Library files periodically to make sure the printer has data for any new label supplies. Also, update if you have ordered a custom label supply from Brady and it came with new Label Library files.

To upgrade the label library files using a USB drive:

1. On a computer, go to the technical support website for your region. See [Technical Support and Registration on page iv](#).
2. Find firmware updates and the most recent BradyJet™ J7300 Printer Label Library update.
3. Download the database update.
4. Extract the files from the zip and save the extracted files to a USB drive.
5. Connect the USB drive to the USB port on the printer and navigate to **Files > Menu** and double-click on "**Import Printer Label Library**" to launch the upgrade.
6. Follow the instructions on the touchscreen. When the upgrade is complete, the printer restarts.

# 6 Troubleshooting

---

Use the following pages to troubleshoot and diagnose possible performance problems with your printer. If the corrective action suggested does not work, visit the Knowledge Base or contact Brady's Technical Support Group. See [Technical Support and Registration on page iv](#).

## Help

Pressing the Help icon on the home screen will provide pictorial instruction for common functions.

## Status Lights

To disable the status light, follow the steps shown in [LED Lights on page 22](#).

**Ready/Idle**



**Warning Message**



**Action Required**













## Print Quality Issues



Below is table of potential print quality issues. Often times the problem can be resolved through a maintenance routine or cleaning.

**Run through the steps directly below, unless the corrective action in the table indicates a different solution.**

1. Check the ink levels in [Material Details on page 7](#).
2. Run [Aligning the Ink Cartridge on page 34](#).
3. Wipe the printhead on the ink cartridge with a dry lint-free cloth.
4. [Installing or Replacing an Ink Cartridge on page 17](#)

Print Distortions	Definition	Corrective Action
Blurry or not aligned 	Image is distorted, less sharp and has reduced level of detail	
Banding 	Horizontal or vertical lines, streaks or bands showing noticeable jumps in tone level	Remove and reinstall the labels. See <a href="#">Working with Labels and Ink Cartridges on page 14</a> .  Try a different <a href="#">Print Mode on page 26</a> .
Grainy/Noisy 	Rough or course coloring.	
Mottled 	Uneven ink or color density - larger scale defect	
Thinning (text, barcode) 	Uneven or narrow ink output on label surface	
Voids 	Missed or lack of a drop on label surface	

Print Distortions		Definition	Corrective Action
Haze		Discoloration or cloudy image on surface	
Color to color alignment		day to day change in color in a hue	<p>Try a different <a href="#">Print Mode on page 26</a>. If the problem is not resolved, continue with the next action.</p> <p>Confirm that the recommended operating conditions are being met. See <a href="#">Physical and Environmental Characteristics on page 2</a>.</p> <p>Replace the ink cartridge. See <a href="#">Installing or Replacing an Ink Cartridge on page 17</a>.</p>
Color change within a label		inconsistent color	<p>Try a different <a href="#">Print Mode on page 26</a>. If the problem is not resolved, continue with the next action.</p> <p>Confirm that the recommended operating conditions are being met. See <a href="#">Physical and Environmental Characteristics on page 2</a>.</p> <p>Replace the ink cartridge. See <a href="#">Installing or Replacing an Ink Cartridge on page 17</a>.</p>
Smearing		Ink is spread across the surface obscuring the printed text or barcode	

Print Distortions		Definition	Corrective Action
Bleed/Bloom (text, barcode)		Spread of ink on label surface	<p>Try a different <a href="#">Print Mode on page 26</a>. If the problem is not resolved, continue with the next action.</p> <p>Confirm that the recommended operating conditions are being met. See <a href="#">Physical and Environmental Characteristics on page 2</a>.</p> <p>Replace the ink cartridge. See <a href="#">Installing or Replacing an Ink Cartridge on page 17</a>.</p>
Drift		Printing is crooked on the label.	Make sure the guide is pushed to the edge of the liner.

## Warning and Error Messages

When the printer experiences an error or communicates a warning message, the message will be displayed on the touchscreen and the status light will change accordingly.

Message on Screen	LED Color on Printer	Corrective Action
The printhead has become too hot.	<b>Red</b>	Wait for the printhead to cool. When the message disappears, the printer is ready for use.
An error occurred while printing.	<b>Red</b>	Open the ink access cover and check for debris. Reseat both ink cartridges and make sure the ink cartridge cover is fully seated.
A hardware issue was detected with one or more ink cartridges.	<b>Red</b>	Replace both ink cartridges to continue printing.
The ink access cover is open.	<b>Red</b>	Lift and close the ink access cover. You should hear the carriage perform the homing routine.

Message on Screen	LED Color on Printer	Corrective Action
Out of labels.	<b>Red</b>	Remove any labels from the exit chute. Press the Unload icon on the home screen. Open the label cover and replace the label roll.
Out of ink in Slot 1.	<b>Red</b>	Replace the black ink cartridge and press Yes on the message to run Ink Cartridge Alignment.
Out of ink in Slot 2.	<b>Red</b>	Replace the CMY ink cartridge and press Yes on the message to run Ink Cartridge Alignment.
Printer cannot sense the loaded label roll.	<b>Red</b>	Confirm that the label roll is correctly installed and the smart-cell is aligned properly. See <a href="#">Installing Labels on page 14</a> .  Use only Brady Authentic labels.
Printer cannot sense the ink cartridge in Slot 1.	<b>Red</b>	Confirm that the black ink cartridge is correctly installed and that the cartridge carriage cover is closed.
Printer cannot sense the ink cartridge in Slot 2.	<b>Red</b>	Confirm that the CMY ink cartridge is correctly installed and that the cartridge carriage cover is closed.
The smart-cell indicates that no labels remain.	<b>Red</b>	Replace the label roll.
Labels are jammed in label path.	<b>Red</b>	<ol style="list-style-type: none"> <li>1. Press Unload on the touchscreen then remove the label roll. Cut off bent or damaged labels, reload label roll.</li> <li>2. Make sure the labels are seated correctly and snug against the media guide.</li> <li>3. Check the label path to see if any parts need cleaning. See <a href="#">Cleaning the Printer on page 32</a>.</li> </ol>

Message on Screen	LED Color on Printer	Corrective Action
The cutter is jammed.	<b>Red</b>	<ol style="list-style-type: none"> <li>1. Press Unload on the touchscreen.</li> <li>2. Open the ink access cover and remove any obstruction from the cutter area.</li> <li>3. Close the ink access cover.</li> <li>4. Tap the Feed icon followed by the Cut icon, on the touchscreen, to cycle the cutter.</li> </ol>
Ink cartridge is not in printing position.	<b>Red</b>	Open the ink access cover and remove any label debris. Close ink access to cover to reinitialize.
Labels are not loaded correctly.	<b>Red</b>	See <a href="#">Installing Labels on page 14</a> .
Cannot connect to network.	<b>Red</b>	Check that the Ethernet cable has not become dislodged. Confirm that the connection settings are correct.
Cannot connect to wireless network.	<b>Red</b>	The Wi-Fi may be down in your facility or the printer was not connected properly. Confirm that the connection settings are correct.
The system memory is low.	<b>Red</b>	<p>The print job or label length is too large for available system memory.</p> <p>To check available memory, go to Settings &gt; About on the printer.</p>
An error occurred while importing print jobs.	<b>Red</b>	Make sure the USB drive is plugged into the printer. Check the About screen for adequate available memory.
Ink cartridge alignment failed.	<b>Red</b>	<p>Reseat both ink cartridges and make sure the ink cartridge cover is fully seated. Verify the label roll is installed correctly. Run <a href="#">Aligning the Ink Cartridge on page 34</a>.</p> <p>If the problem persists, make sure a bright light is not shining down on the printer which may be interfering with an internal sensor.</p> <p>If the problem remains, cover the clear window and run <a href="#">Aligning the Ink Cartridge on page 34</a> again.</p>

Message on Screen	LED Color on Printer	Corrective Action
The system could not read the printer's Label Library file.	<b>Orange</b>	Follow instructions for <a href="#">Diagnostics on page 36</a> .
Storage space for print jobs is getting low.	<b>Orange</b>	Wait for the current print job to complete before starting the next print job.
Ink low in Slot 1.	<b>Orange</b>	The black cartridge is low on ink. If quality still looks acceptable you can choose to ignore this warning. However, you may waste labels if the cartridge runs out of ink before the next warning at 0%.
Ink low in Slot 2.	<b>Orange</b>	The CMY cartridge is low on ink. If quality still looks acceptable you can choose to ignore this warning. However, you may waste labels if the cartridge runs out of ink before the next warning at 0%.
Cartridge alignment recommended. This will use ink and require a label roll at least 2.95" wide to be installed.	<b>Orange</b>	See <a href="#">Aligning the Ink Cartridge on page 34</a> .
External USB is unavailable.	<b>Blue</b>	Jobs will be stored in internal memory until USB is plugged in.
The print job uses labels <Parameter>.Label <Parameter> is loaded in the printer. Turn on "Ignore Wrong Labels" in Settings to hide this message.	<b>Blue</b>	Install the labels prompted by the printer.

# 7 Label Specifications

**IMPORTANT!** Test all custom made label supply with the intended printer before ordering large quantities! Brady will only guarantee custom label supply ordered from Brady.

- Continuous label supply (JC-4000-2595)
- Pre-sized label supply (J-19-2475)

## Continuous Labels

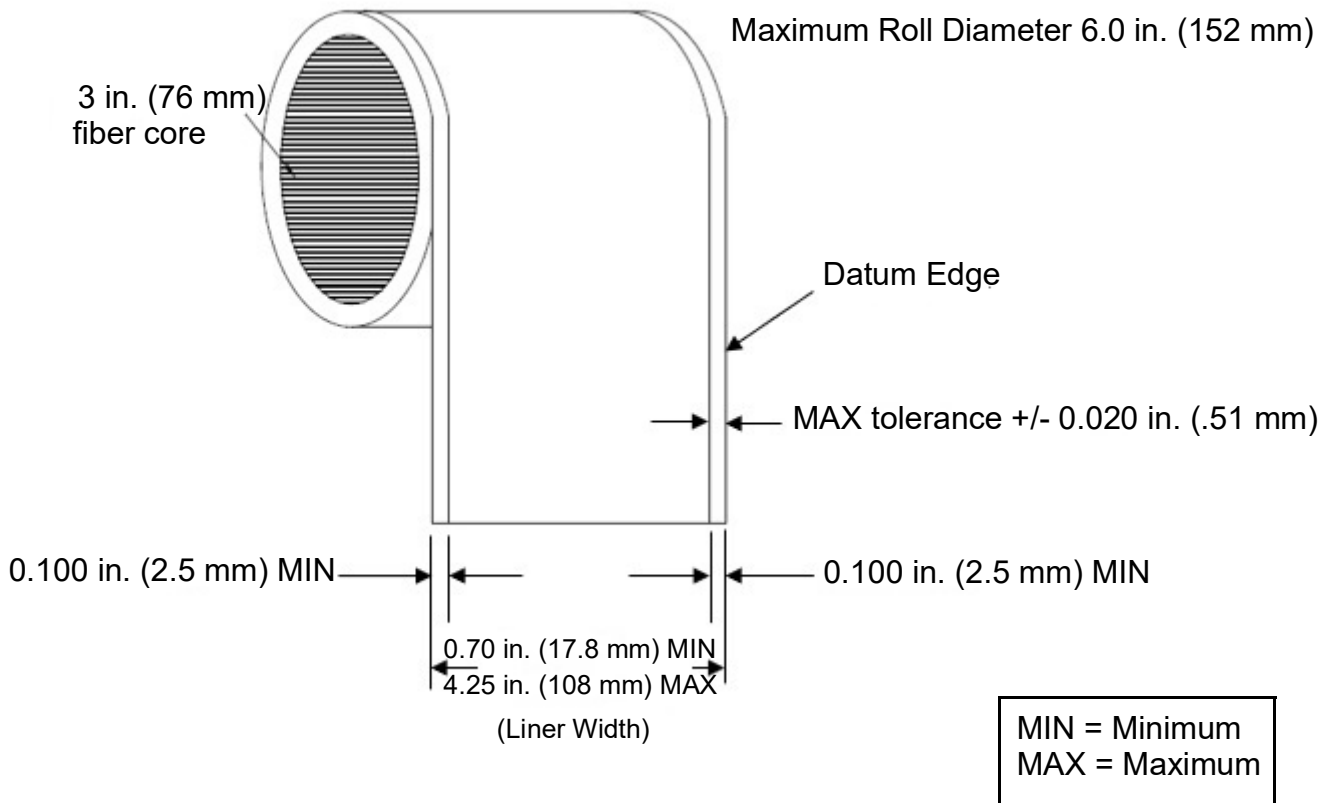

## Pre-Sized Labels (Notched)

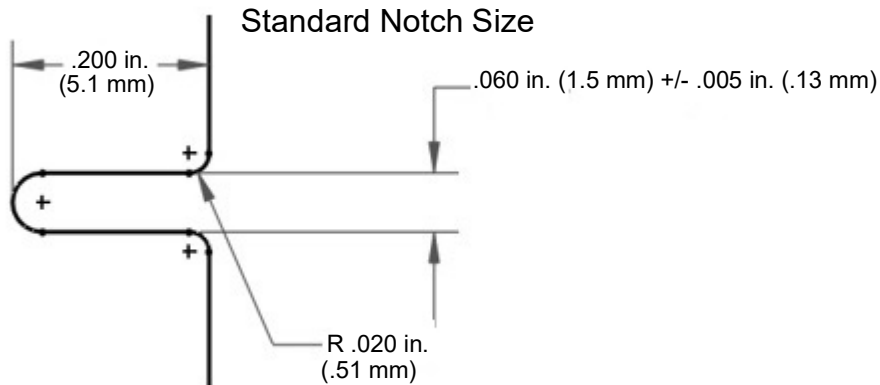
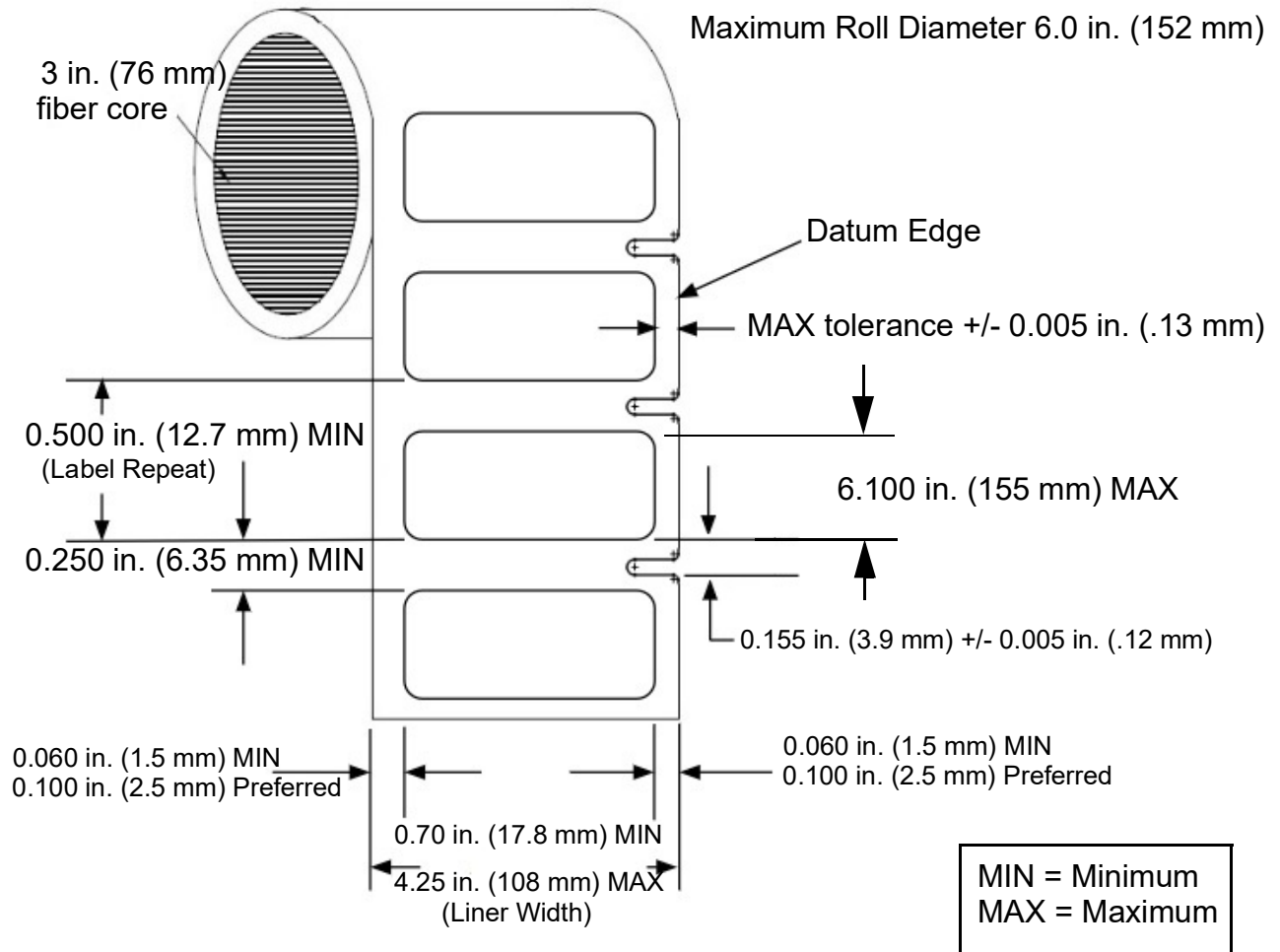

## Pre-Sized Labels (Gap)

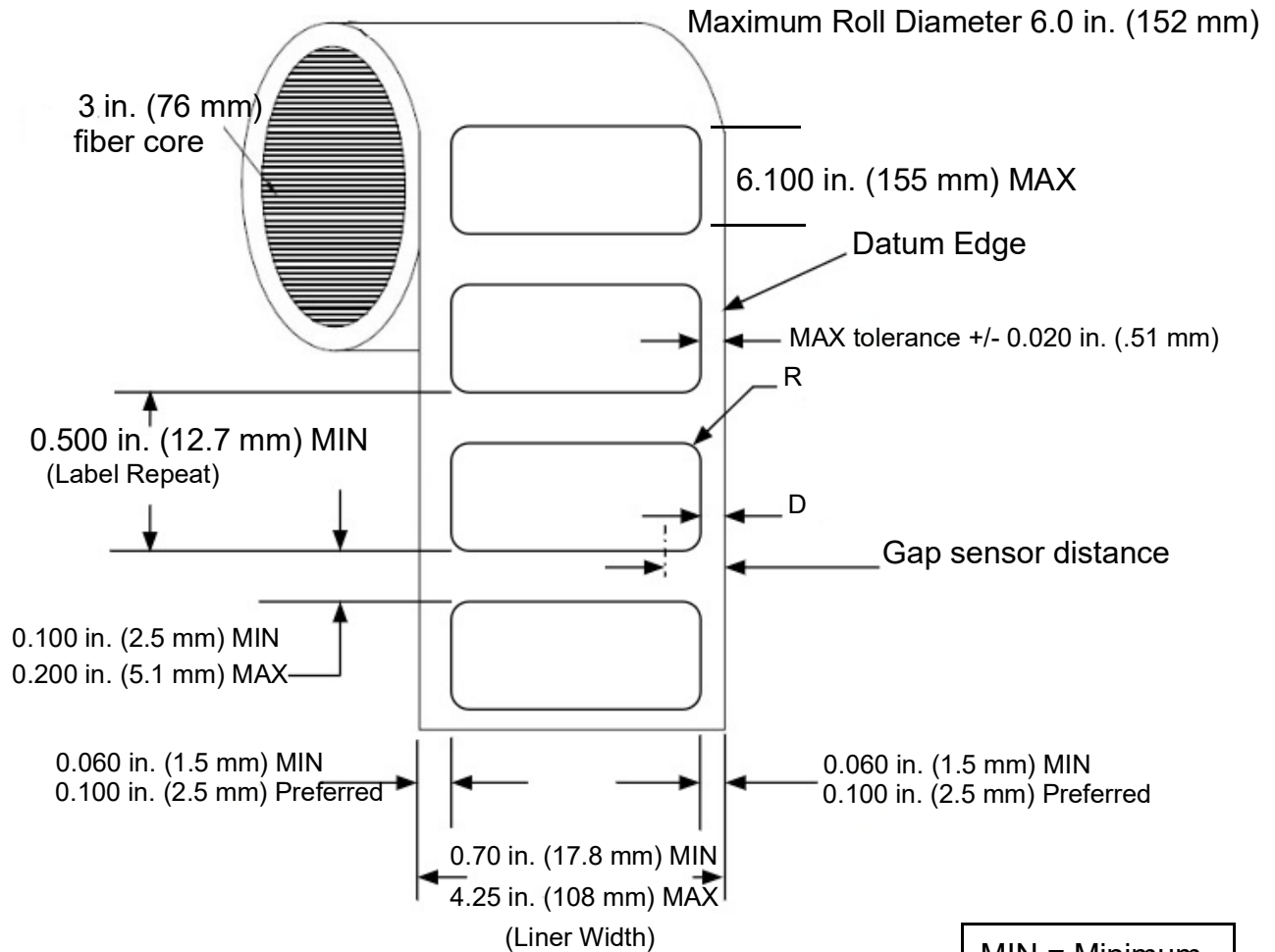

MIN = Minimum  
MAX = Maximum

To guarantee the gap sensor can sense the leading edge of the label, the label radius (R) and waste strip edge distance (D) must comply with the following formula:  $R + D < 0.416$  inches (10.566 mm).

# Linerless Labels (Notched)

Maximum Roll Diameter 6.0 in. (152 mm)

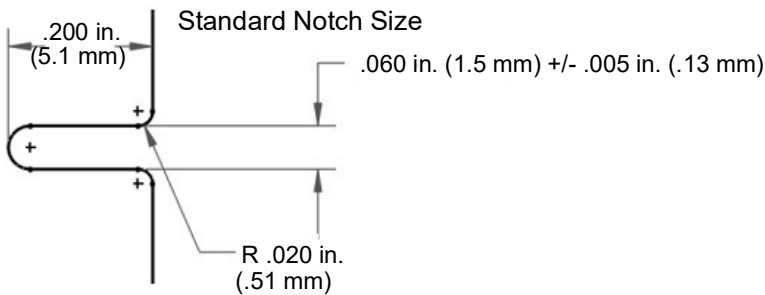
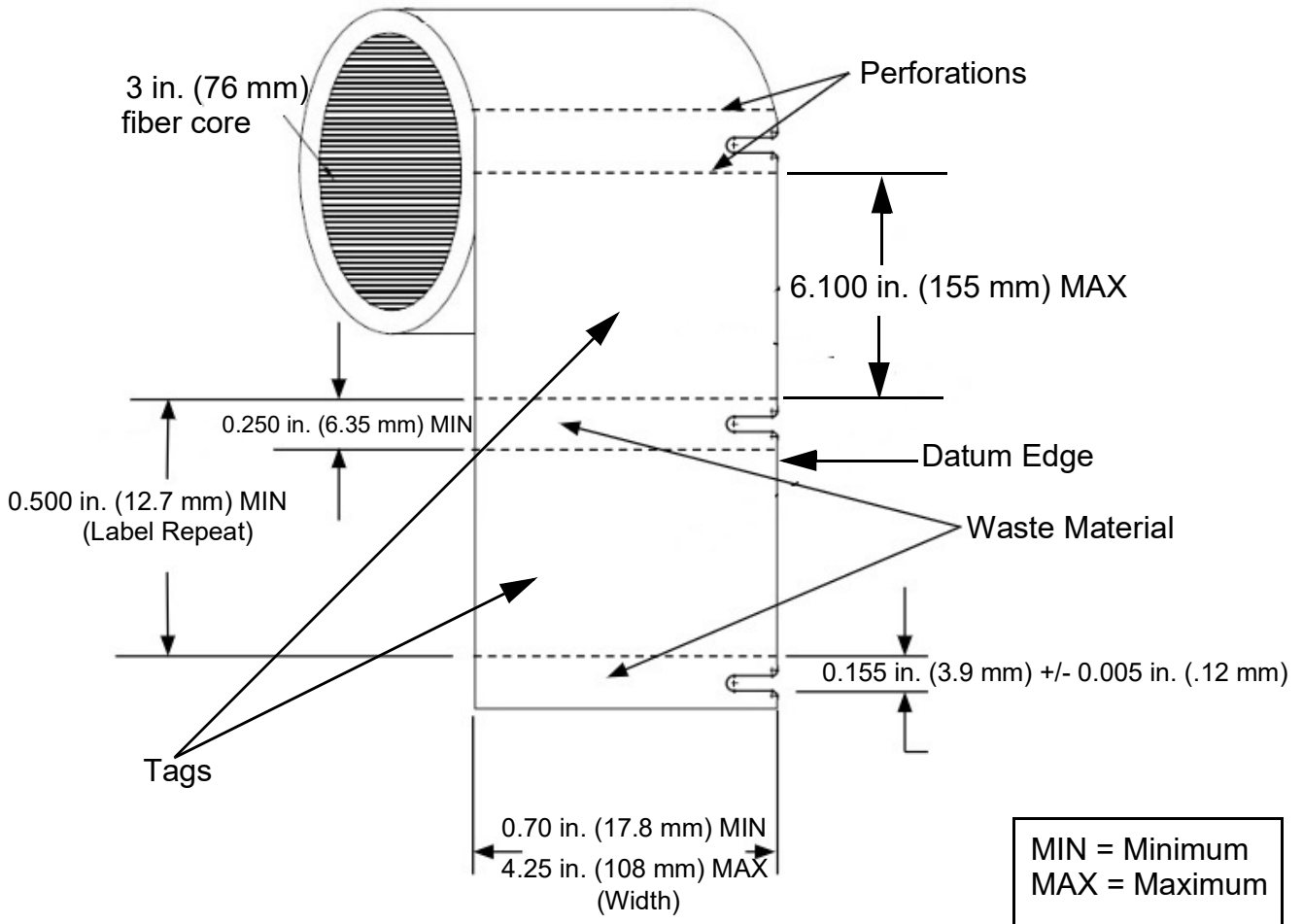

# 8 Glossary

---

This glossary provides definitions of printer specific, as well as more commonly used terms.

## Printer

<b>Capping</b>	The printhead is covered when not in use to protect from damage, evaporation.
<b>Calibration (Materials)</b>	A process the printer automatically does to align materials with the sensor for accurate printing registration and start of job.
<b>Ink Maintenance Routine</b>	An automated sequence of spitting* and wiping** by the printer to clean printhead nozzles and remove any potential blockages.
<b>Saturation</b>	The intensity of a selected color on the computer screen, which affects the amount of ink applied and thereby dry time and print quality.
<b>*Spitting</b>	An ejection of drops which clear the printhead nozzles and remove any potential clogs.
<b>**Wiping</b>	Removal of excess ink and debris from the printhead nozzle plate.

## Color

<b>Color Conversion Tools</b>	On-line color converters that will assist the user to get the best possible match with Pantone® colors within the technical limitations of process color technology.
<b>Color Gamut</b>	The volume of three dimensional color space that a device (monitor or printer) can achieve.
<b>Color Space</b>	A three dimensional plot of the measured color values.
<b>CMY Process Color</b>	A color model that combines <b>Cyan</b> , <b>Magenta</b> and <b>Yellow</b> to make colors whereby black and dark colors are processed and therefore not as deep or dark.
<b>CMYK Process Color</b>	A color model that refers to four ink colors ( <b>Cyan</b> , <b>Magenta</b> , <b>Yellow</b> and <b>Key</b> [Black]) to create a printed image.
<b>Delta E</b>	A measurement of the change in color correlating to statistically relevant perceptible color change by the human eye.
<b>Pantone</b>	The coloring system made by Pantone LLC used to ensure a color match using Pantone certified (non-inkjet) inks. Due to the differences in inkjet technology, inkjet colors may not perfectly match all Pantone colors.

<b>RGB Luminous Color</b>	Standard default for images on computer screens. Light is introduced on screen which therefore may be brighter than printed output. Often referred to as “additive color.”
<b>Spot Color</b>	Solid color created using a specific premixed ink (non-process color).
<b>Subtractive Color</b>	Process by which inks are placed onto a white background to create a printed image within the color gamut.

## Ink Types

<b>Aqueous</b>	Ink with water as the principal carrier for the colorant
<b>Dye</b>	Ink with soluble colorant
<b>Pigment</b>	Ink with insoluble colorant
<b>Solvent</b>	Ink with solvent(s) as the principal carrier for the colorant

## Common Ink Jet Terms

<b>Ink Cartridge</b>	A component of the inkjet system that includes the ink, printhead and nozzles. Printhead is typically disposable.
<b>Inkjet Printing</b>	Non-contact form of printing that recreates a digital image by propelling droplets of ink from a printhead onto substrates.
<b>Inkjet Receptive Topcoat</b>	A coating on the substrate* that is optimized for the ink to be evenly absorbed, assure good print quality and provide durability.
<b>Nozzle</b>	The small opening in the ink chamber on the ink cartridge from which the ink is ejected.
<b>Printhead</b>	A component of the inkjet system containing an array of nozzles able to eject small drops of ink.
<b>*Substrate</b>	Base material optimized for the correct environment and application. Also provides the surface on which the topcoat is applied.
<b>Thermal Ink Jet (TIJ)</b>	Inkjet technology wherein the ink is heated rapidly to grow a bubble and eject a drop. BradyJet J7300 uses TIJ.
<b>Topcoat</b>	The type of coating that is used on the final layer of the blank unprinted material.

# A Regulatory Compliance

---

## Agency Compliance and Approvals

### United States

#### *FCC Notice*

This equipment has been tested and found to comply with the limits for a Class A digital device, pursuant to part 15 of the FCC Rules. These limits are designed to provide reasonable protection against harmful interference when the equipment is operated in a commercial environment. This equipment generates, uses, and can radiate radio frequency energy and, if not installed and used in accordance with the instruction manual, may cause harmful interference to radio communications.

Operation of this equipment in a residential area may cause harmful interference in which case the user will be required to correct the interference at his own expense.

In instances where interference is experienced, the following measures are recommended to assist in mitigation:

- Reorient or reposition the equipment relative to the interference.
- Increase the separation distance between the equipment and the interference.
- Connect equipment to a separate power circuit than the interference if applicable.

Changes or modifications not expressly approved by the party responsible for compliance could void the user's authority to operate the equipment.

This device complies with Part 15 of the FCC Rules. Operation is subject to the following two conditions: (1) This device may not cause harmful interference and, (2) this device must accept any interference received, including interference that may cause undesired operation.

### Estados Unidos

#### *Aviso de la FCC*

Este equipo se puso a prueba y se confirmó que cumple con los límites para un dispositivo digital de Clase A, conforme a la Parte 15 de las Regulaciones de la Comisión Federal de Comunicaciones (Federal Communications Commission, FCC). Estos límites se han diseñado para proporcionar protección razonable contra interferencias perjudiciales cuando el equipo se utilice en un entorno comercial. Este equipo genera, utiliza y puede emitir energía de radiofrecuencia y, si no se instala y se utiliza según el manual de instrucciones, puede ocasionar interferencias perjudiciales en las radiocomunicaciones.

El uso de este equipo en un área residencial puede causar interferencias perjudiciales, en cuyo caso el usuario tendrá que corregir dichas interferencias por su cuenta.

En los casos donde se producen interferencias, se recomiendan las siguientes medias para ayudar a mitigarlas:

- Volver a orientar o reposicionar el equipo para evitar la interferencia.
- Aumente la distancia de separación entre el equipo y la interferencia.
- Si es posible, conecte el equipo a un circuito eléctrico distinto al de las interferencias.

Los cambios o las modificaciones que no hayan sido aprobados expresamente por la parte responsable del cumplimiento pueden invalidar la autorización que se le otorga al usuario para utilizar el equipo.

Este dispositivo cumple con la Parte 15 de las Regulaciones de la FCC. El uso está sujeto a las siguientes dos condiciones: (1) es posible que este dispositivo no provoque interferencias perjudiciales y (2) este dispositivo debe aceptar cualquier interferencia recibida, incluso aquella que pueda generar un uso no deseado.

## **Canada**

Innovation, Science and Economic Development (ISED)

Canada ICES-003: Information Technology Equipment (including Digital Apparatus)

Canada NMB-003: Équipement de technologie de l'information (incluant les appareils numériques)

CAN ICES-3 (A)/NMB-3(A)

## Europe



**WARNING!** This is a Class A product. In a domestic environment, this product may cause radio interference in which case the user may be required to take adequate measures.



### **Waste Electrical and Electronic Equipment Directive**

In accordance with the European WEEE Directive, this device needs to be recycled in accordance with local regulations.

### ***RoHS Directive 2011/65/EU, 2015/863/EU***

This product is CE marked and complies with the European Union's Directive 2011/65/EU OF THE EUROPEAN PARLIAMENT AND OF THE COUNCIL of 8 June 2011 on the restriction of the use of certain hazardous substances in electrical and electronic equipment.

EU Directive 2015/863 of 31 March 2015 (RoHS 3) amends Annex II to Directive 2011/65/EU of the European Parliament and of the Council as regards the list of restricted substances.

### ***Batteries Directive 2006/66/EC***



This product contains a lithium coin cell battery. The crossed-out wheeled bin shown to the left is used to indicate 'separate collection' for all batteries and accumulators in accordance with European Directive 2006/66/EC. Users of batteries must not dispose of batteries as unsorted municipal waste. This Directive determines the framework for the return and recycling of used batteries and accumulators that are to be collected separately and recycled at end of life. Please dispose of the battery according to your local regulations.

### **Notice to Recyclers**

#### **To remove the lithium coin cell battery:**

1. Disassemble printer and locate the lithium coin cell battery located on the main circuit board.
2. Using a small screwdriver, pry the battery from its holder and remove the battery from the board. Dispose of in accordance with local regulations.

## China

China RoHS Hazardous Substance Table related to this product is available at [www.bradyid.com/J7300compliance](http://www.bradyid.com/J7300compliance).

### **警告**

此为 A 级产品。在生活环境中，该产品可能会造成无线电干扰。在这种情况下，可能需要用户对于干扰采取切实可行的措施。

仅适用于非热带气候条件下安全使用

仅适用于海拔2000m 以下地区安全使用。

## Taiwan

### Class A Statement

警告：為避免電磁干擾，本產品不應安裝或使用於住宅環境

Taiwan Restricted Substances Containment Status (RoHS Declaration) related to this product is available at [www.BradyID.com/J7300compliance](http://www.BradyID.com/J7300compliance).

### Importer:

香港商貝迪香港有限公司

臺北市中山區南京東路3段101號4樓

BRADY CORPORATION HONG KONG LIMITED

4th Floor, No. 101, Section 3, Nanjing East Road, Zhongshan District, Taipei City

## Turkey

Turkish Ministry of Environment and Forestry

(Directive on the Restriction of the use of certain hazardous substances in electrical and electronic equipment).

Türkiye Cumhuriyeti: EEE Yönetmeliğine Uygundur

## Wireless Regulatory Information

*Applies to the Wi-Fi module only included in printer models that support wireless communication.*

Regulatory markings, subject to country certification, are applied to host printer signifying Wi-Fi and Bluetooth (radio) approvals have been obtained.



**WARNING!** Operation of the device without regulatory approval for the region in which the equipment is being operated is illegal.

Radio protocol	WLAN IEEE 802.11b/g/n
RF Operating Frequency	2.4 – 2.495 GHz
RF Output Power	< +20dBm EIRP (100mW)
Antenna Type \ Antenna Gain	PCB trace antenna \ 2.3 dBi
Environmental Operation	-40 to 85° C (-40° to 185° F) <b>Note:</b> Be mindful of the maximum operating temperatures for the printer. See <a href="#">Environmental Ranges on page 2</a> .
Environmental Storage	-55 to 125° C (-67° to 257° F) <b>Note:</b> Be mindful of the maximum storage temperatures for the printer. See <a href="#">Environmental Ranges on page 2</a> .

### United States

**Note:** This equipment has been tested and found to comply with the limits for a Class A digital device, pursuant to part 15 of the FCC Rules. These limits are designed to provide reasonable protection against harmful interference when the equipment is operated in a commercial environment. This equipment generates, uses, and can radiate radio frequency energy and, if not installed and used in accordance with the instruction manual, may cause harmful interference to radio communications.

Operation of this equipment in a residential area is likely to cause harmful interference in which case the user will be required to correct the interference at own expense.

Changes or modifications not expressly approved by the party responsible for compliance could void the user's authority to operate the equipment.

This device complies with Part 15 of the FCC Rules. Operation is subject to the following two conditions: (1) This device may not cause harmful interference and, (2) this device must accept any interference received, including interference that may cause undesired operation.

**Co-located statements:** To comply with FCC RF exposure compliance requirement, the antenna used for this transmitter must not be co-located or operating in conjunction with any other transmitter/antenna except those already with radio module filing.

**RF exposure guidelines / Important note:** This equipment complies with FCC SAR exemption limits set forth for an uncontrolled environment when properly used as instructed.

## Mexico

IFT notice: La operación de este equipo está sujeta a las siguientes dos condiciones: (1) es posible que este equipo o dispositivo no cause interferencia perjudicial y (2) este equipo o dispositivo debe aceptar cualquier interferencia, incluyendo la que pueda causar su operación no deseada.

## Canada

Innovation, Science and Economic Development (ISED)

CAN ICES-3 (A)/NMB-3(A)

This device contains license-exempt transmitter(s)/receiver(s) that comply with Innovation, Science and Economic Development Canada's license-exempt RSSs. Operation is subject to the following two conditions:

1. This device may not cause interference; and
2. This device must accept any interference, including interference that may cause undesired operation of the device.

Le présent appareil est conforme aux CNR Innovation, Sciences et Développement économique Canada applicables aux appareils radio exempts de licence. L'exploitation est autorisée aux deux conditions suivantes:

1. l'appareil ne doit pas produire de brouillage;
2. l'utilisateur de l'appareil doit accepter tout brouillage radioélectrique subi, même si le brouillage est susceptible d'en compromettre le fonctionnement.

**Co-located statements:** To comply with IC RF exposure compliance requirement, the antenna used for this transmitter must not be co-located or operating in conjunction with any other transmitter/antenna except those already with radio module filing.

**RF exposure guidelines / Important note:** This equipment complies with ISED radiation exposure exemption limits set forth in RSS-102 for an uncontrolled environment when properly used as instructed.

## European Union

This is a Class A product. In a domestic environment, this product may cause radio interference in which case the user may be required to take adequate measures.

Radio Equipment Directive (RED) 2014/53/EU

- a. Frequency band(s) in which the radio equipment operates; 2.412GHz to 2.462GHz
- b. Maximum radio-frequency power transmitted in the frequency band(s) in which the radio equipment operates; <+20dBm EIRP (100mW)

This device is a 2.4 GHz wideband transmission system (transceiver), intended for use in all EU member states and EFTA countries, except in France and Italy where restrictive use applies.

In Italy the end-user should apply for a license at the national spectrum authorities in order to obtain authorization to use the device for setting up outdoor radio links and/or for supplying public access to telecommunications and/or network services.

This device may not be used for setting up outdoor radio links in France and in some areas the RF output power may be limited to 10 mW EIRP in the frequency range of 2454 - 2483.5 MHz. For detailed information the end-user should contact the national spectrum authority in France.

### Country Specific Statements

български [Bulgarian] С настоящото Технология Брейди декларира, че това устройство J7300 е в съответствие със съществените изисквания и други приложими разпоредби на Директиви 2014/53/EU

Hrvatski [Croatian] Tehnologija Brady ovim putem izjavljuje da je ovaj uređaj J7300 sukladan osnovnim zahtjevima i ostalim bitnim odredbama Direktiva 2014/53/EU

Česky [Czech] Technologie Brady tímto prohlašuje, že tento J7300 je ve shodě se základními požadavky a dalšími příslušnými ustanoveními směrnice 2014/53/EU.

Dansk [Danish] Undertegnede Brady teknologi erklærer herved, at følgende udstyr J7300 overholder de væsentlige krav og øvrige relevante krav i direktiv 2014/53/EU.

Deutsch [German] Hiermit erklärt Brady-Technologie, dass sich das Gerät J7300 in Übereinstimmung mit den grundlegenden Anforderungen und den übrigen einschlägigen Bestimmungen der Richtlinie 2014/53/EU befindet.

Eesti [Estonian] Käesolevaga kinnitab Brady tehnoloogia seadme J7300 vastavust direktiivi 2014/53/EU põhinõuetele ja nimetatud direktiivist tulenevatele teistele asjakohastele sätetele.

English Hereby, Brady Technology, declares that this J7300 is in compliance with the essential requirements and other relevant provisions of Directive 2014/53/EU.

Español [Spanish] Por medio de la presente Tecnología Brady declara que el J7300 cumple con los requisitos esenciales y cualesquiera otras disposiciones aplicables o exigibles de la Directiva 2014/53/EU.

Ελληνική [Greek] ΜΕ ΤΗΝ ΠΑΡΟΥΣΑ Τεχνολογία Brady ΔΗΛΩΝΕΙ ΟΤΙ J7300 ΣΥΜΜΟΡΦΩΝΕΤΑΙ ΠΡΟΣ ΤΙΣ ΟΥΣΙΩΔΕΙΣ ΑΠΑΙΤΗΣΕΙΣ ΚΑΙ ΤΙΣ ΛΟΙΠΕΣ ΣΧΕΤΙΚΕΣ ΔΙΑΤΑΞΕΙΣ ΤΗΣ ΟΔΗΓΙΑΣ 2014/53/EU.

Français [French] Par la présente Technologie Brady déclare que l'appareil J7300 est conforme aux exigences essentielles et aux autres dispositions pertinentes de la directive 2014/53/EU.

Íslenska [Icelandic] Hér, Brady tækni, því yfir að þetta J7300 tæki er í samræmi við grunnkröfur og önnur viðeigandi ákvæði tilskipana 2014/53/ EU

Italiano [Italian] Con la presente Tecnologia Brady dichiara che questo J7300 è conforme ai requisiti essenziali ed alle altre disposizioni pertinenti stabilite dalla direttiva 2014/53/EU.

Latviešu valoda [Latvian] Aršo Brady tehnoloģija deklarē, ka J7300 atbilst Direktīvas 2014/53/EU būtiskajām prasībām un citiemar to saistītajiem noteikumiem.

Lietuvių kalba [Lithuanian] Šiuo Brady technologija deklaruoja, kad šis J7300 atitinka esminius reikalavimus ir kitas 2014/53/EU Direktyvos nuostatas.

Nederlands [Dutch] Hierbij verklaart Brady-technologie dat het toestel J7300 in overeenstemming is met de essentiële eisen en de andere relevante bepalingen van richtlijn 2014/53/EU.

Malti [Maltese] Hawnhekk, Teknologija Brady, jiddikjara li dan J7300 jikkonforma mal-ħtiġijiet essenzjali u ma provvedimenti oħrajn relevanti li hemm fid-Dirrettiva 2014/53/EU.

Magyar [Hungarian] Alulírott, Brady technológia nyilatkozik, hogy a J7300 megfelel a vonatkozó alapvető követelményeknek és az 2014/53/EU irányelv egyéb előírásainak.

Norsk [Norwegian] Herved Brady-teknologi, erklærer at denne J7300 enheten, er i samsvar med de grunnleggende kravene og andre relevante bestemmelser i direktivene 2014/53/EU

Polski [Polish] Niniejszym Technologia Brady'ego oświadcza, że J7300 jest zgodny z zasadniczymi wymogami oraz pozostałymi stosownymi postanowieniami Dyrektywy 2014/53/EU.

Português [Portuguese] Tecnologia Brady declara que este J7300 está conforme com os requisitos essenciais e outras disposições da Directiva 2014/53/EU.

Română [Romanian] Prin prezenta, Tehnologia Brady declară că acest dispozitiv J7300 este în conformitate cu cerințele esențiale și alte prevederi relevante ale Directivei 2014/53/EU

Slovenščina [Slovenian] Tehnologija Brady izjavlja, da je ta J7300 v skladu z bistvenimi zahtevami in ostalimi relevantnimi določili direktive 2014/53/EU.

Slovenčina [Slovak] Technológia Brady týmtovyhlasuje, že J7300 spĺňa základné požiadavky a všetky príslušné ustanovenia Smernice 2014/53/EU.

Suomi [Finnish] Brady tekniikka vakuuttaa täten että J7300 tyyppinen laite on direktiivin 2014/53/EU oleellisten vaatimusten ja sitä koskevien direktiivin muiden ehtojen mukainen.

Svenska [Swedish] Härmed intygar Brady-teknik att denna J7300 står i överensstämmelse med de väsentliga egenskapskrav och övriga relevanta bestämmelser som framgår av direktiv 2014/53/EU

## Japan

MIC \ TELECOM: 201-220017

当該機器には電波法に基づく、技術基準適合証明等を受けた特定無線設備を装着している。

## Mexico

IFT notice:

"La operación de este equipo está sujeta a las siguientes dos condiciones: (1) es posible que este equipo o dispositivo no cause interferencia perjudicial y (2) este equipo o dispositivo debe aceptar cualquier interferencia, incluyendo la que pueda causar su operación no deseada."

## International

The Wi-Fi radio module used in Brady host printers comply with internationally recognized standards covering human exposure to electromagnetic fields, i.e. EN 62311 "Assessment of electronic and electrical equipment related to human exposure restrictions for electromagnetic fields (0 Hz - 300 GHz)".

## United Kingdom

This is a Class A product. In a domestic environment, this product may cause radio interference in which case the user may be required to take adequate measures.

Radio Equipment Regulations 2017

Electromagnetic Compatibility Regulations 2016

Electrical Equipment (Safety) Regulations 2016

- a. Frequency band(s) in which the radio equipment operates; 2.401GHz to 2.483GHz
- b. Maximum radio-frequency power transmitted in the frequency band(s) in which the radio equipment operates; < +20dBm EIRP (100mW)